

Motordata:

- Un = 24VDC
- Phase = 3
- Poles = 8
- Line resistance = 0,46 ±10% Ohm
- Line inductance = 0,33 ±20% mH
- No-load speed = 5000 1/min
- rated torque = 0,23 Nm
- rated speed = 4000 1/min
- rated output power = 96 Watt
- electrical time constant = 0,65 ms
- Torque constant = 0,045 N/A
- Voltage constant = 4,8 Volt/1000 1/min
- rated current = 5,4 A
- Isolation class B

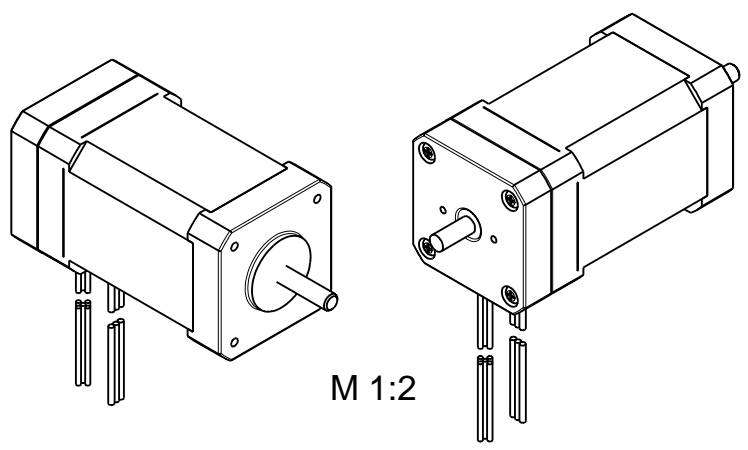
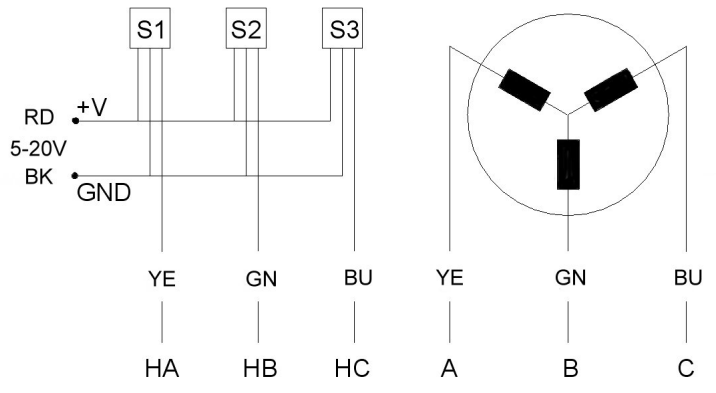

Schutzvermerk DIN ISO 16016 beachten

Index		Änderung		Datum	Name
2022	Datum	Name			
Bearb.	24.08.	GK			
Gepr.	25.08.2022	MK			

Allgemeintoleranz	
ISO 2768 - m	



www.ott-antriebe.de

Ott GmbH & Co.KG
D-78652 Deißlingen
Tel.:0049-07420-93990

Maßstab	1:1	Original A3
Werkstoff / Rohteil		
Benennung		
BLDC-Motor with B-Side-Shaft		
Zg.Nr.	42BL3SL07-08	Blatt