



Induction Motor



Induction Motor

Index

Outline of Induction Motor	B-07
Induction Motor 6W (□ 60mm)	B-09
Induction Motor 6W (□ 70mm)	B-11
Induction Motor 10W (□ 70mm)	B-13
Induction Motor 15W (□ 70mm)	B-15
Induction Motor 15W (□ 80mm)	B-17
Induction Motor 25W (□ 80mm)	B-20
Induction Motor 40W (□ 90mm)	B-23
Induction Motor 60W (□ 90mm)	B-26
Induction Motor 90W (□ 90mm)	B-30
Induction Motor 120W (□ 90mm)	B-34
Induction Motor 150W (□ 90mm)	B-38
Induction Motor 180W (□ 90mm)	B-41
Induction Motor 200W (□ 90mm)	B-44
Induction Motor 250W (□ 104mm)	B-47
Induction Motor 300W (□ 104mm)	B-50
Induction Motor 400W (□ 104mm)	B-53

DKM AC/DC Geared Motor and Gearbox **B-06**

Änderungen und Irrtümer auch technischer Art vorbehalten!

B AC Motors

Outline of Induction Motor

☐ Suitable for Unidirectional Continuous Operation

- Induction motors are suitable for unidirectional continuous operation such as conveyor belt system.

☐ Single Phase Run

- For the running of a single phase motor, please use the capacitor complying with the capacity of the motor. For a single phase induction motor, it is not possible to reverse the direction within a short time during operation. So stop the motor first and change the direction next. (Figure 1)

☐ Three Phase Run

- Three phase induction motor has relatively high starting torque comparing single phase motor and has high reliability because it can be directly operated by a three phase power source. (Figure 2)

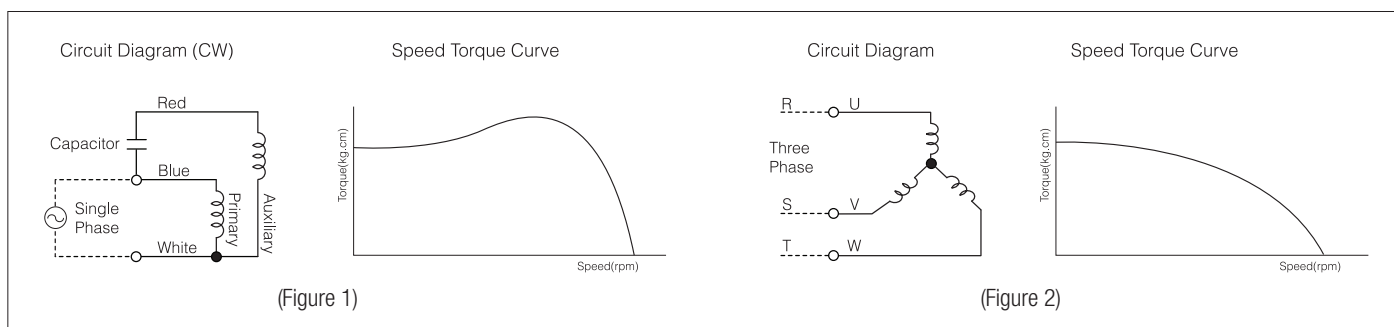

☐ The Relation between Speed and Torque

- In a condition of constant power voltage, the relation between speed and torque is like next figure. Under the condition of no-load, the number of rotation is roughly same as the number of synchronous rotation. But if the load increases, the number of rotation decreases and approaches to the speed (r/min) indicated by the point P where the torque T_p horizontally meets the load curve. When the load further increases and reaches the point M, the motor stops at the point R because the motor no longer generates further torque. Therefore, the leg R-M is referred to as an unstable zone and the leg O-M is a stable zone for operation.

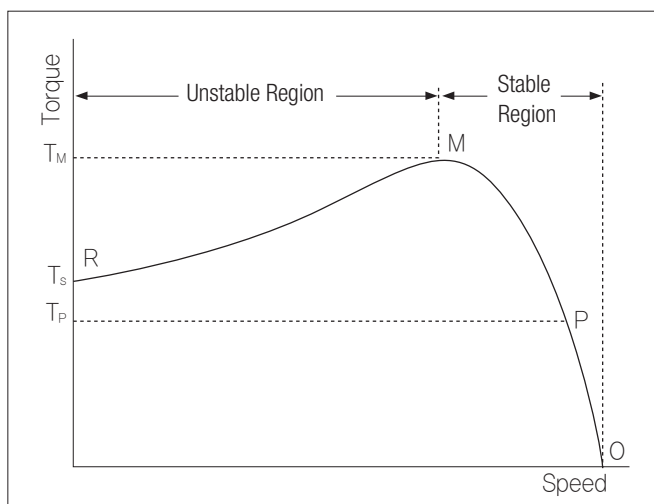

☐ Features of Voltage and Capacitor

- Generally the torque of induction motor changes proportionate to twice the voltage and it also changes according the capacity of the capacitor. If the capacity of the capacitor increases, the starting torque and rated torque will increase. But if the capacity increases by over 2 times, the rated torque decreases and starting torque do not increase. When the induction motor is short on torque, it is possible to increase the torque by increasing the voltage or the capacity of the capacitor to continue the operation. But please be informed that in this case the loss input of the motor increases and the temperature rises rapidly. However, if the motor must be run with insufficient torque, take measures to let the motor release heat as much as possible by installing separate fan as an example and operate the motor while keeping the temperature of the motor's housing below 90°C .

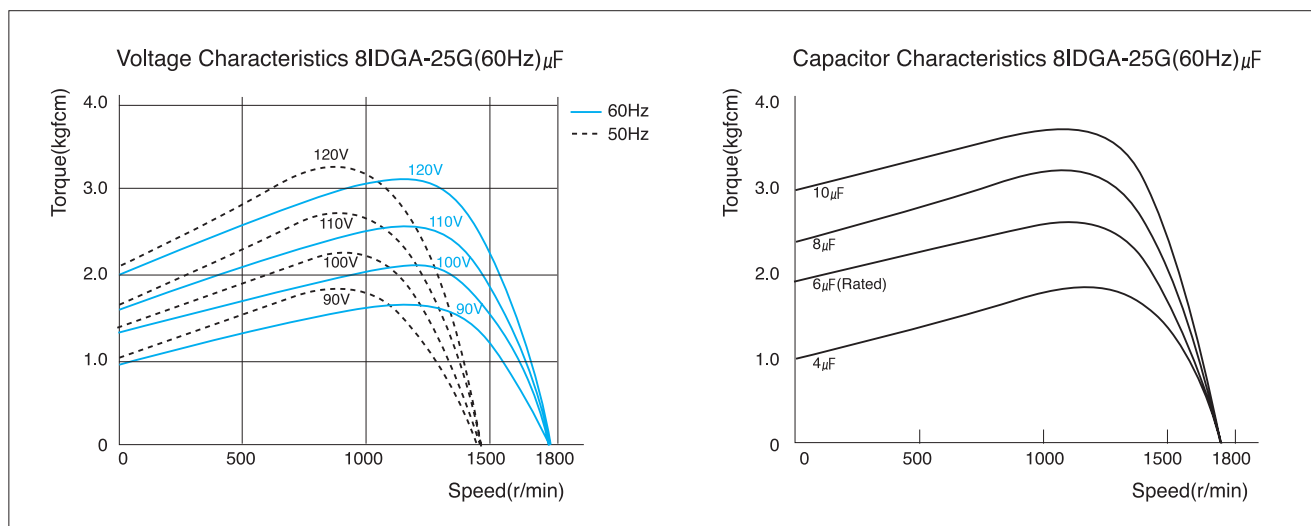

General Specifications

Item	Specification
Insulation Resistance	100MΩ or more when DC500V MEGA is applied between the windings and the frame after rated motor operation under normal ambient temperature and humidity.
Dielectric Strength	Sufficient to withstand 1.5KV at 50Hz and 60Hz applied between the windings and the frame for 1 minute after rated motor operation under normal ambient temperature and humidity.
Temperature Rise	Temperature rise of windings are 80°C or less measured by the resistance change method after rated motor operation with connecting a Gearbox or equivalent heat radiation plate.
Insulation Class	Class B [130°C]
Overheat Protection	Operating temperature (Built-in thermal protector type motor): Open 120°C±5°C, Close 90°C±5°C
Ambient Temperature	-10°C~+40°C (Three phase 220VAC: -10°C~+50°C)
Ambient Humidity	85% maximum

Connection Diagrams

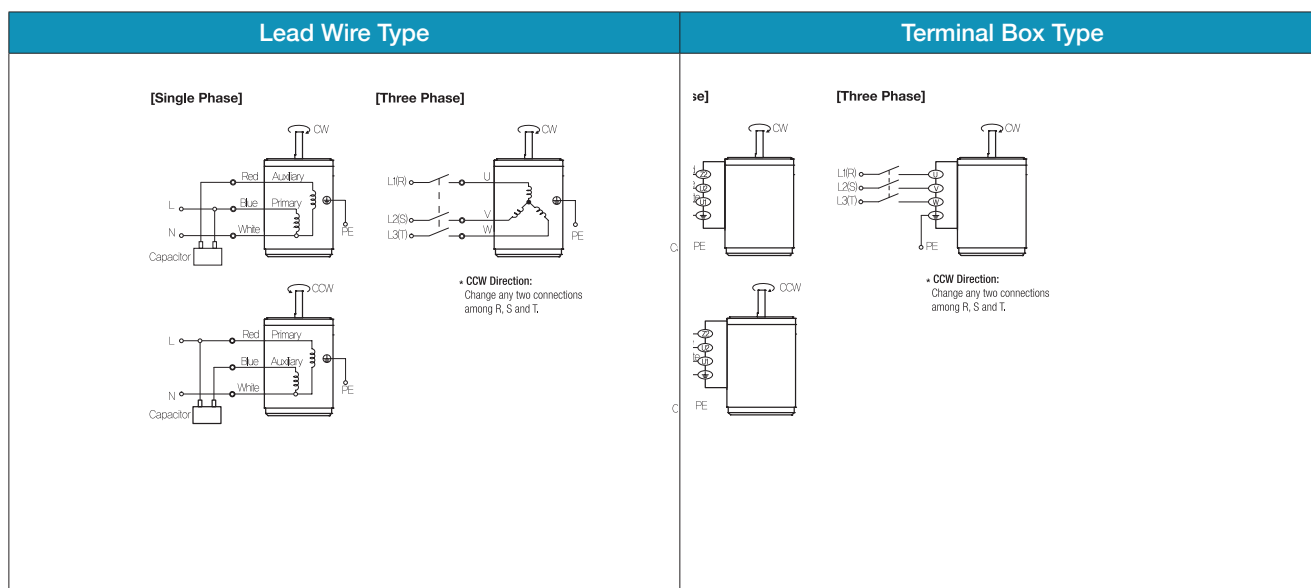

A Information

I Product Coding System

AC Motors

Motor

- I** : Induction Motor
- R** : Reversible Motor
- B** : Electromagnetic Brake Motor
- Cl** : Clutch & Brake Motor
- T** : Torque Motor
- S** : Speed Control Induction Motor
- SR** : Speed Control Reversible Motor
- SB** : Speed Control . Brake Motor
- CS** : Speed Control Clutch & Brake Motor

Phase & Voltage

- 1 : 1Ø AC 110V 60Hz
- 2 : 1Ø AC 220V 60Hz
- 3 : 3Ø AC 220~230V 50/60Hz
- 4 : 3Ø AC 380V~400V 50/60Hz
- 5 : 3Ø AC 415V~440V 50/60Hz
- 6 : 3Ø AC 220/380V 60Hz
- 7 : 3Ø AC 230/400V 50Hz
- 8 : 3Ø AC 440V 50/60Hz

Phase & Voltage

[Built-in Thermal Protector Type]

- A** : 1Ø AC 110V 60Hz
- D** : 1Ø AC 220V 60Hz
- E** : 1Ø AC 220~240V 50Hz
- G** : 3Ø AC 220V 50/60Hz
- K** : 3Ø AC 380V~400V 50/60Hz
- L** : 3Ø AC 415V~440V 50/60Hz

Fan Type

- F** : General Fan (Self Cooling)
- F2** : Powerful Fan (Separate Fan Motor)
Powerful fan makes powerful cooling performance rotating in high speed regardless of motor shaft speed.
- No Mark** : Without Fan

Connection Type

- T** : Terminal Box Type
- No Mark** : Lead Wire Type

Pole

- A** : 2 Pole
- No Mark** : 4 Pole

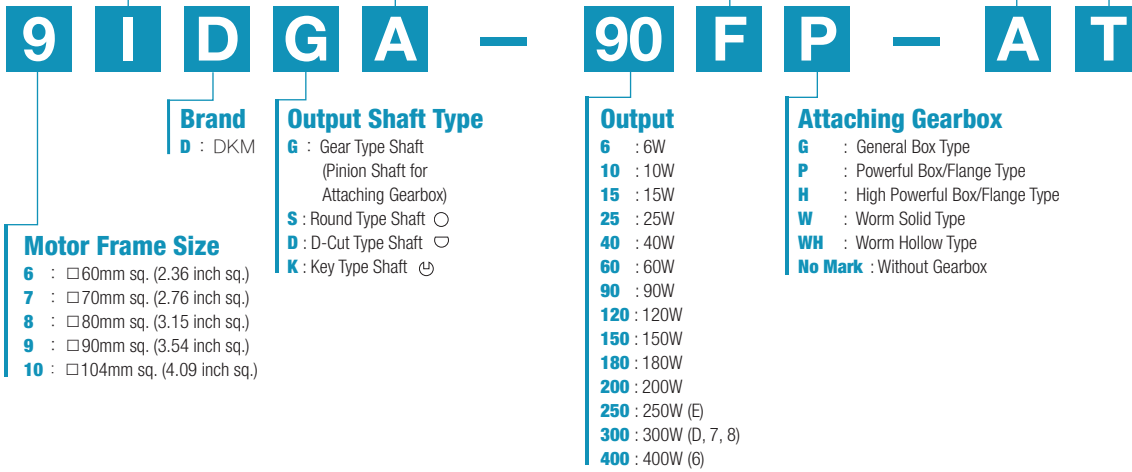

DC Motors

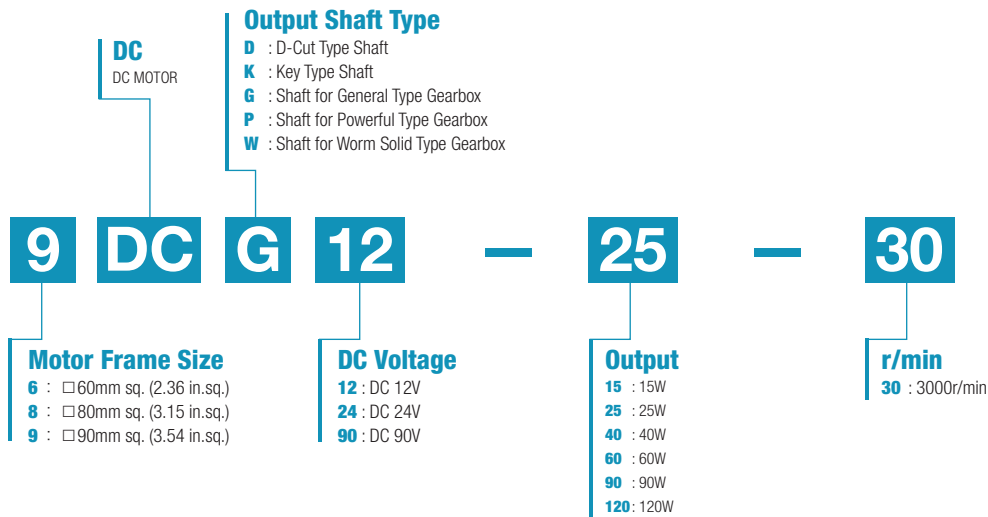

Parallel Gearbox

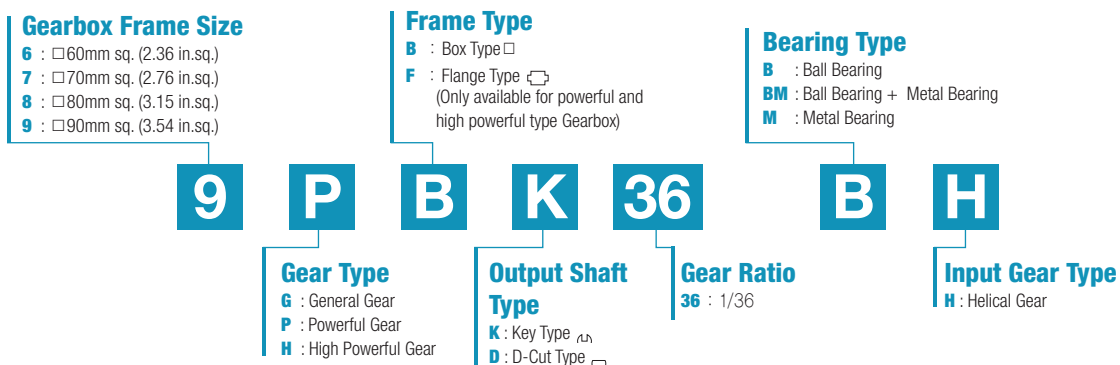

Worm Solid Gearbox

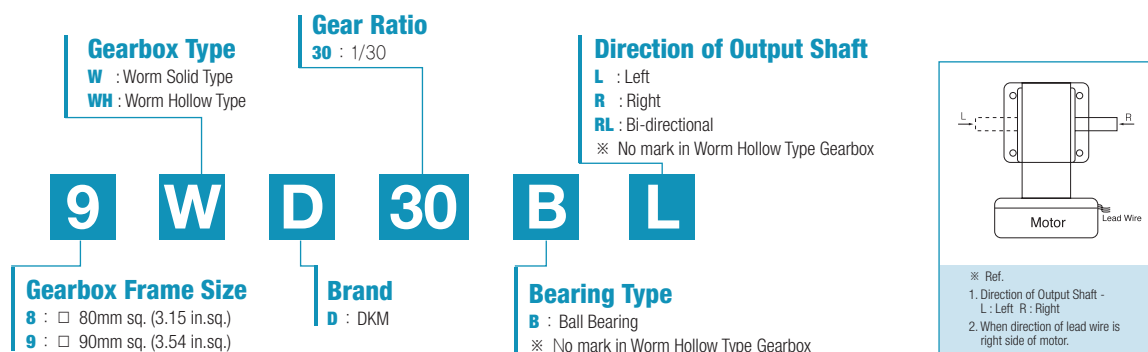

Worm Hollow Gearbox

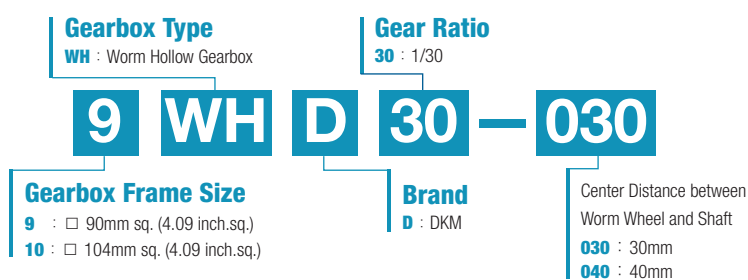

Inter-decimal Gearbox

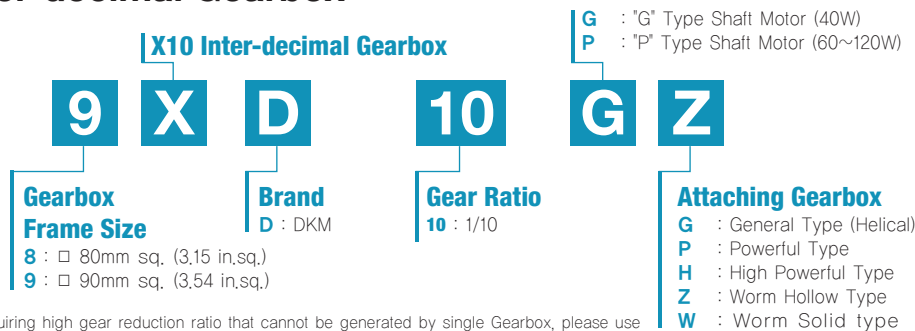

In case of requiring high gear reduction ratio that cannot be generated by single Gearbox, please use Inter-decimal Gearbox with general Gearbox. And please be advised that in this case only revolution speed of output shaft will reduce by 10:1 without increasing of maximum permissible torque.

A Information

Product Coding System

Assembly of Motor and Gearbox

Motor + Gearbox

- As shown in the following scheme, motor and Gearbox which have same frame size and gear type could be assembled.

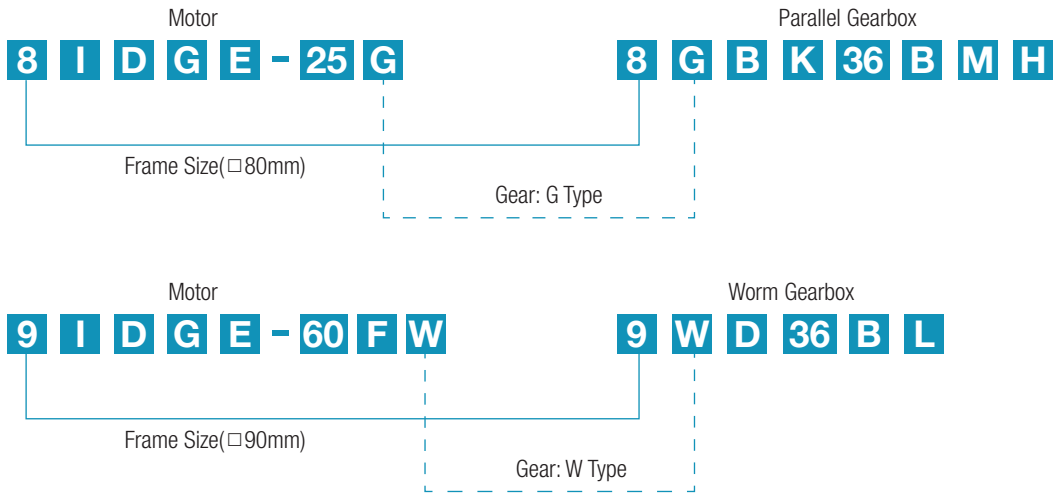

Motor + Inter-decimal Gearbox + Gearbox

- When using an inter-decimal Gearbox together, give attention to the gear types of motor, Gearbox and inter-decimal Gearbox.

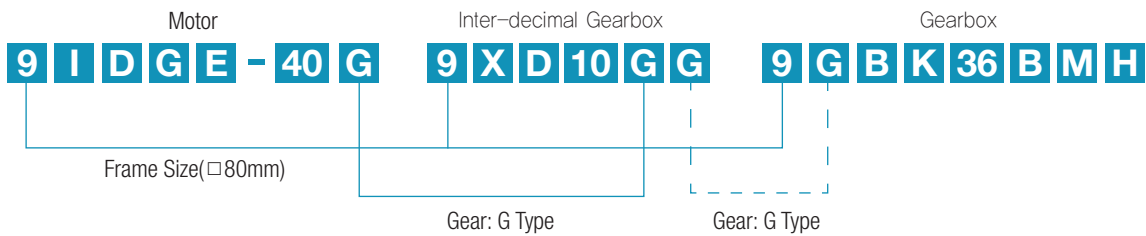

- When attaching inter-decimal Gearbox, the output shaft type of the motor is always G type. For example, when using P/H/W/WH type Gearbox, only the gear type of inter-decimal Gearbox is identical with attached Gearbox and the output shaft type of the motor is G type. (Refer to the scheme below.)

B AC Motors

Induction Motor 15W(□ 80mm)

15W Induction Motor 15W(□ 80mm)

Motor Specification

Model		Output W	Voltage V	Frequency Hz	Poles	Duty	Starting Torque		Rated Load			Capacitor μF / VAC	
Lead Wire Type	Terminal Box Type						kgfcm	N.m	Speed r/min	Current A	Torque kgfcm N.m		
8IDG ⁺ -15□(-T)	8IDGA-15□-T	15	1∅110	60	4	Cont.	0.84	0.084	1600	0.39	0.98	0.098	3.5 / 450
8IDG ⁻ -15□(-T)	8IDGD-15□-T	15	1∅220	60	4	Cont.	1.40	0.140	1600	0.22	1.10	0.110	1.2 / 450
8IDGE-15□	8IDGE-15□-T	15	1∅220	50	4	Cont.	1.05	0.105	1250	0.17	1.17	0.117	1.2 / 450
			1∅240				1.20	0.120		0.18	1.30	0.130	
8IDGG-15□	8IDGG-15□-T	15	3∅220	50	4	Cont.	4.80	0.480	1300	0.22	1.40	0.140	-
				60			4.00	0.400	1600	0.18	1.00	0.100	
8IDGK-15□	8IDGK-15□-T	15	3∅380	50	4	Cont.	4.60	0.460	1300	0.13	1.20	0.120	-
				60			3.60	0.360	1550	0.11	1.00	0.100	
			3∅400	50	4	Cont.	5.00	0.500	1300	0.14	1.40	0.140	
				60			4.00	0.400	1600	0.12	1.00	0.100	
			3∅415	50	4	Cont.	5.40	0.540	1350	0.15	1.20	0.120	
				60			4.20	0.420	1600	0.13	1.00	0.100	
			3∅440	50	4	Cont.	6.00	0.600	1350	0.16	1.40	0.140	
				60			4.60	0.460	1600	0.14	1.40	0.140	

- 1) Enter the phase & voltage code in the place * and enter the model type of attaching Gearbox in the box (□) within the motor model name.
 - 2) All models contain a built-in thermal protector.
 - 3) Gear Type Shaft is for attaching Gearbox and D-Cut Type Shaft is for using motor only.
- * It is not possible to use inverter for three phase 380-440V motor. When inverter is used, the insulation of winding coil becomes hot and may cause damage to the motor.

Max. Permissible Torque at Output Shaft of Gearbox

60Hz

Motor Model	Gearbox Model	Gear Ratio	3	3.6	5	6	7.5	9	12.5	15	18	25	30	36	40	50	60	75	90	100	120	150	180
8IDG□-15G	8GBK□BMH	r/min	600	500	360	300	240	200	144	120	100	72	60	50	45	36	30	24	20	18	15	12	10
		kgfcm	3.0	3.6	5.0	6.0	7.5	9.0	12.5	14.9	17.9	22.5	27.0	29.4	32.6	40.8	49.0	61.2	73.4	80.0	80.0	80.0	80.0
		N.m	0.29	0.35	0.49	0.59	0.73	0.88	1.22	1.46	1.76	2.21	2.65	2.88	3.20	4.00	4.80	6.00	7.20	7.84	7.84	7.84	7.84

Motor Model	Gearbox Model	Gear Ratio	200	250	300	360
8IDG□-15G	8GBK□BMH	r/min	9	7	6	5
		kgfcm	80.0	80.0	80.0	80.0
		N.m	7.84	7.84	7.84	7.84

Motor Model	Gearbox Model	Gear Ratio	10	12	15	18	25	30	36	50	60
8IDG□-15W	8WD□BL/□BR/□BRL	r/min	180	150	120	100	72	60	50	36	30
		kgfcm	9.8	11.5	13.9	16.0	21.0	23.8	27.6	36.0	39.6
		N.m	0.96	1.13	1.36	1.57	2.06	2.33	2.71	3.53	3.88

50Hz

Motor Model	Gearbox Model	Gear Ratio	3	3.6	5	6	7.5	9	12.5	15	18	25	30	36	40	50	60	75	90	100	120	150	180
8IDG□-15G	8GBK□BMH	r/min	500	417	300	250	200	167	120	100	83	60	50	42	38	30	25	20	17	15	13	10	8
		kgfcm	3.5	4.2	5.8	7.0	8.7	10.5	14.5	17.4	20.9	26.3	31.5	34.3	38.1	47.6	57.1	71.4	80.0	80.0	80.0	80.0	80.0
		N.m	0.34	0.41	0.57	0.68	0.85	1.02	1.42	1.71	2.05	2.57	3.09	3.36	3.73	4.66	5.60	7.00	7.84	7.84	7.84	7.84	7.84

Motor Model	Gearbox Model	Gear Ratio	200	250	300	360
8IDG□-15G	8GBK□BMH	r/min	7	6	5	5
		kgfcm	80.0	80.0	80.0	80.0
		N.m	7.84	7.84	7.84	7.84

Motor Model	Gearbox Model	Gear Ratio	10	12	15	18	25	30	36	50	60
8IDG□-15W	8WD□BL/□BR/□BRL	r/min	150	125	100	83	60	50	42	30	25
		kgfcm	11.5	13.4	16.2	18.6	24.5	27.7	32.3	42.0	46.2
		N.m	1.13	1.32	1.58	1.83	2.40	2.72	3.16	4.12	4.53

- 1) Enter the phase & voltage code in the box (□) within the motor model name.
- 2) Enter the gear ratio in the box (□) within the Gearbox model name.
- 3) A colored background indicates gear shaft rotation in the same direction as the motor shaft; a white background indicates rotation in the opposite direction.
- 4) The rotating speed is calculated by dividing the motor's synchronous speed (50Hz: 1,500r/min, 60Hz: 1,800r/min) by the gear ratio. The actual speed is 2-20% less than the displayed value, depending on the size of the load.

Dimensions

MOTOR ONLY

- MOTOR MODEL: 8IDD□-15(-T) (NO FAN)

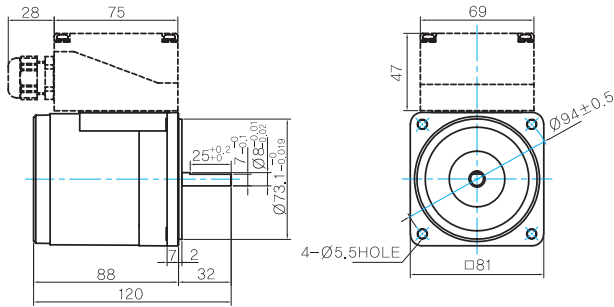

MOTOR OUTPUT SHAFT

MODEL	SPEC
D-CUT TYPE	

INTER-DECIMAL GEARBOX

- MODEL: 8XD10□□

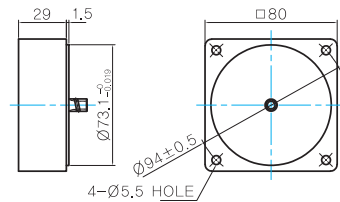

GEARED MOTOR

G TYPE GEARBOX

- MOTOR MODEL: 8IDG□-15G (NO FAN)

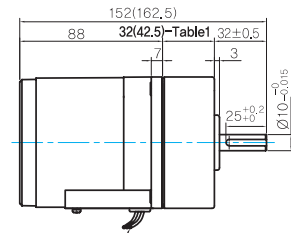

LEAD WIRE 300mm
UL STYLE NO.3271 AWG NO.22

- GEARBOX MODEL: 8GBK□BMH

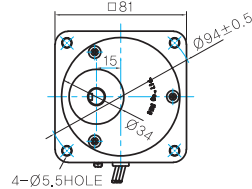

GEARHEAD OUTPUT SHAFT

MODEL	SPEC
KEY TYPE	

KEY SPEC

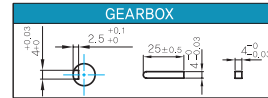

- 32(42.5)-Table1

SIZE(mm)	GEAR RATIO
32	8GBK3BMH - 8GBK18BMH
42.5	8GBK25BMH - 8GBK360BMH

W TYPE GEARBOX

- MOTOR MODEL: 8IDG□-15W (NO FAN)

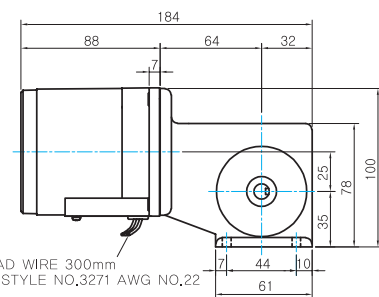

LEAD WIRE 300mm
UL STYLE NO.3271 AWG NO.22

- GEARBOX MODEL: 8WD□BL/BR/BRL

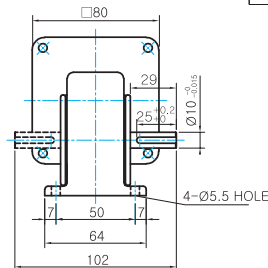

KEY SPEC

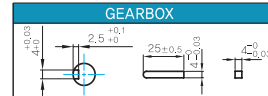

WEIGHT

PART	WEIGHT(Kg)
MOTOR	1,6
8GBK3BMH - 8GBK18BMH	0,48
8GBK25BMH - 8GBK30BMH	0,61
8GBK36BMH - 8GBK180BMH	0,67
8GBK200BMH - 8GBK360BMH	0,63
8WD□BL/BR/BRL	0,67
8XD10□□	0,44

Motor Images

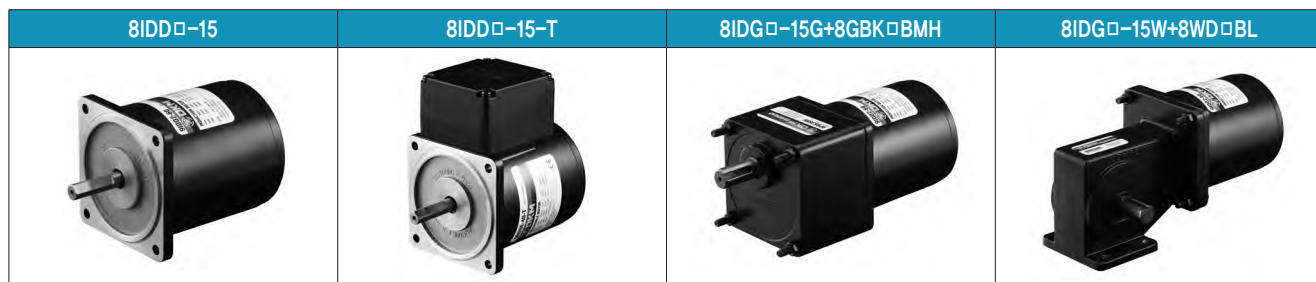

B AC Motors

Induction Motor 15W(□ 80mm)

Connection Diagrams

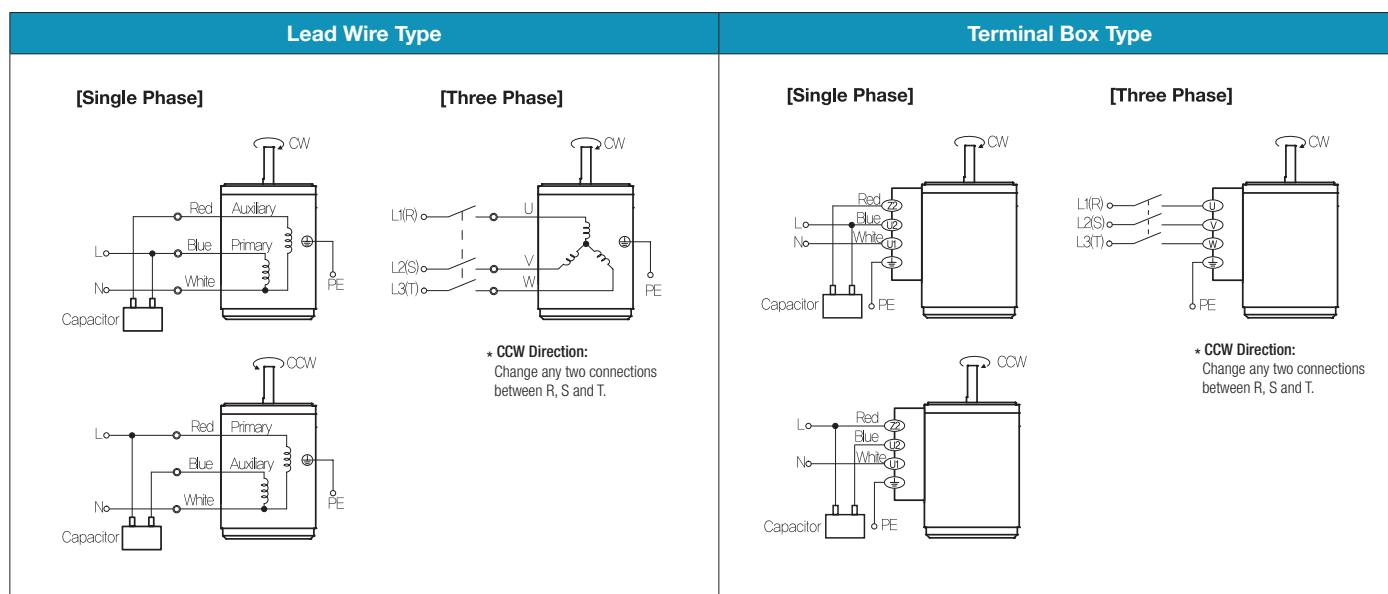

- 1) The direction of motor rotation is as viewed from the shaft end of the motor.
- 2) CW represents the clockwise direction, while CCW represents the counterclockwise direction.
- 3) Change the direction of single phase motor rotation only after bringing the motor to a stop. If an attempt is made to change the direction of rotation while the motor is rotating, the motor may ignore the reversing command or change its direction after some delay.