

DC-, BLDC- UND AC-MOTOREN BIS SCHUTZKLASSE IP66



**MIT SCHNECKEN-, STIRNRAD ODER
PLANETENGETRIEBE**



**Auf allen folgenden Seiten gilt:
Änderungen und Irrtümer
auch technischer Art vorbehalten!**



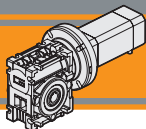

Motoriduttori brushless CC a vite senza fine Brushless DC Wormgearmotors

Caratteristiche tecniche

Technical features

Le caratteristiche principali dei motoriduttori brushless CC a vite senza fine della serie CM sono:

- Alimentazione in bassa tensione 24/36/48 Vcc
- Motore protezione IP55
- Coppie motore disponibili da 0.22 a 4.2 Nm
- Carcasce dei riduttori in pressofusione di alluminio
- Lubrificazione permanente con olio sintetico
- Disponibili anche nella versione con solo riduttore, sia con flangia di entrata standard che con flangia e manicotto dedicati

The main features of CM brushless DC wormgearmotors range are:

- Low voltage power supply 24/36/48 Vdc
- Motor protection IP55
- Motor torque ratings available from 0.22 up to 4.2 Nm
- Die-cast aluminium housings
- Permanent synthetic oil long life lubrication
- Gearbox only version also available, with either standard input flange or customized flange and coupling

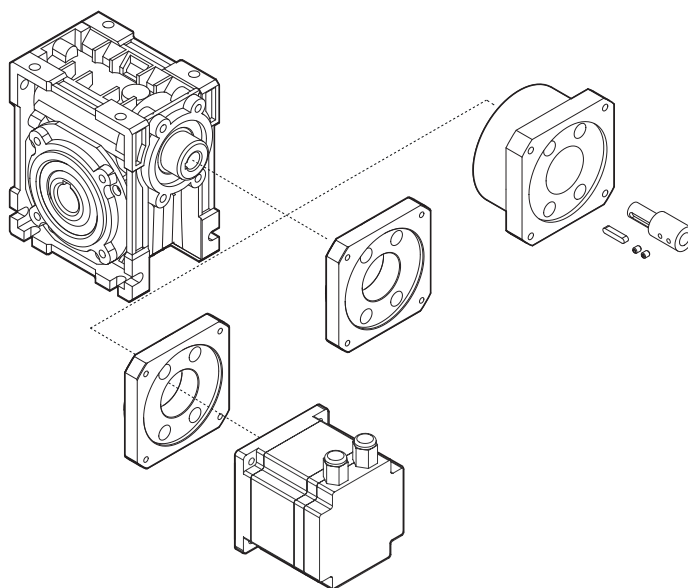

Designazione

Classification

RIDUTTORE / GEARBOX			
CM	030	20	U
Tipo Type	Grandezza Size	Rapporto in Ratio in	Versione Version
CM	026 030 040 050 063 070	Vedere tabelle See tables	U FD FS FLD FLS FBD FBS
			

MOTORE / MOTOR		
BL070.480	48V	BR
Tipo Type	Tensione Voltage	Freno Brake
BLS022.240 BLS043.240 BL070.240 BL070.24B BL070.48B BL070.480 BL070.48.80 BL140.480 BL200.48.95 BL210.480 BL210.48E BL400.48.120	24V-36V 24V-36V 24V 24V 48V 48V 24V-48V 48V 24V-48V 24V-48V 48V 48V	24V 48V
		

Versione Riduttore
Gearbox Version

Albero di uscita
Output shaft

Braccio di reazione
Torque arm

Angolo
Angle

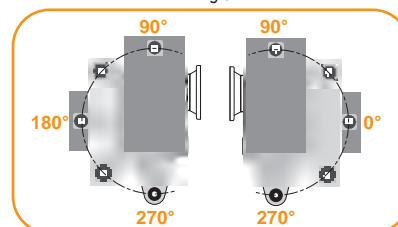
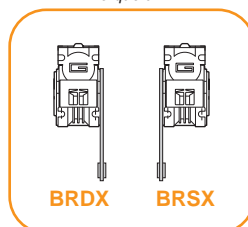
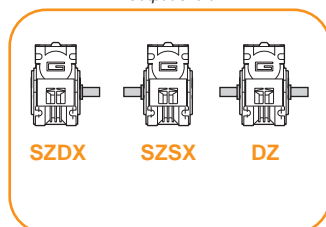
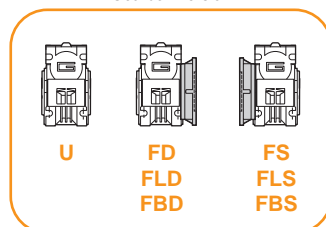

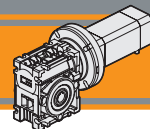

Simbologia

Symbols

Ns	n° stadi / No. stages	n _{1MAX}	[Rpm]	Velocità max entrata / Max input speed
ir	rapporto reale / real ratio	V	[V]	Tensione / Voltage
M ₂	[Nm] coppia in uscita output torque	n ₂	[Rpm]	Velocità in uscita / Output Speed
A ₂	[N] Carico assiale ammissibile in uscita Permitted output axial load	IP		Grado di protezione / Enclosure protection
R ₂	[N] Carico radiale ammissibile in uscita Permitted output radial load	Kg		Peso / Weight
Pn ₁	[kW] Potenza nominale in entrata Nominal input power	sf		Fattore di servizio / Service Factor
Mn ₂	[Nm] Coppia nominale in uscita in funzione di Pn1 Nominal output torque referred to Pn1	Rd	%	Rendimento dinamico / Dynamic efficiency
		Rs	%	Rendimento statico / Static efficiency
		Z		Numero di principi della vite / Worm starts
		β		Angolo d'elica / Helix angle

Lubrificazione e temperatura

Lubrication and temperature

Tutti i motoriduttori CM sono forniti completi di lubrificante sintetico viscosità 320, pertanto possono essere installati in qualunque posizione di montaggio e non necessitano di manutenzione.

Permanent synthetic oil long-life lubrication (viscosity grade 320) makes it possible to use the CM worm gearmotors in all mounting positions; for this reason they can be installed in any assembly position and do not require maintenance.

Temperatura ambiente 0 ÷ 40 °C (in assenza di congelamento ed in assenza di condensa).

Ambient temperature 0 ÷ 40 °C (in the absence of freezing and condensation).

Per temperature diverse, contattare nostro UT.

For temperature outside this range please contact our technical dept.

Carichi radiali

Radial loads

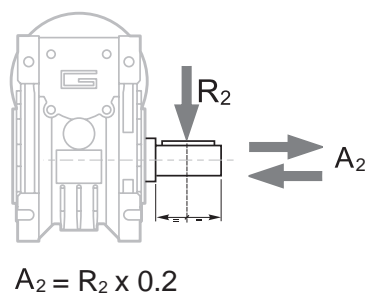

n ₂ [min ⁻¹]	R ₂ [N]					
	CM026	CM030	CM040	CM050	CM063	CM070
600	271	457	857	1200	1657	-
400	310	523	981	1374	1897	2028
300	342	576	1080	1512	2088	2232
200	391	659	1236	1731	2390	2555
150	479	726	1361	1905	2631	2812
120	514	782	1466	2052	2834	3030
100	547	831	1558	2181	3012	3219
75	609	914	1715	2400	3315	3543
60	610	985	1847	2586	3571	3817
50	610	1047	1963	2748	3794	4056
38	610	1147	2151	3011	4158	4445
30	610	1241	2327	3258	4499	4809

Quando il carico radiale risultante non è applicato sulla mezzeria dell'albero occorre calcolare quello effettivo con la seguente formula:

When the resulting radial load is not applied on the centre line of the shaft it is necessary to calculate the effective load with the following formula:

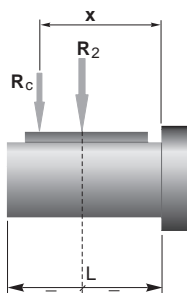

	CM					
	026	030	040	050	063	070
a	56	65	84	101	120	122
b	43	50	64	76	95	92
R _{2MAX}	610	1600	3000	4200	5800	6200

$$R_c = \frac{R_2 \cdot a}{(b + x)} \leq R_{2MAX}$$

a. b = valori riportati nella tabella
a. b = values given in the table

$$R \leq R_c$$

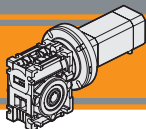

Motoriduttori brushless CC a vite senza fine Brushless DC Wormgearmotors

Dati di dentatura

Toothing data

	Dati della coppia vite-corona Worm wheel data	Rapporto / Ratio											
		5	7.5	10	15	20	25	30	40	50	60	80	100
CM026	Z	6	4	3	2	2		1	1	1	1		
	β	34° 35'	24° 41'	19° 1'	12° 57'	10° 30'		6° 33'	5° 17'	4° 26'	3° 49'		
CM030	Z	6	4	3	2	2	2	1	1	1	1	1	1
	β	27° 4'	24° 28'	18° 50'	12° 49'	10° 23'	8° 43'	6° 29'	5° 14'	4° 23'	3° 46'	2° 57'	2° 25'
CM040	Z	6	4	3	2	2	2	1	1	1	1	1	1
	β	34° 19'	24° 28'	18° 50'	12° 49'	10° 23'	8° 43'	6° 29'	5° 14'	4° 23'	3° 46'	2° 57'	2° 25'
CM050	Z	6	4	3	2	2	2	1	1	1	1	1	1
	β	33° 37'	23° 54'	18° 23'	12° 29'	10° 6'	8° 28'	6° 19'	5° 5'	4° 15'	3° 39'	2° 51'	2° 20'
CM063	Z	6	4	3	2	2	2	1	1	1	1	1	1
	β	34° 23'	24° 31'	18° 53'	12° 50'	10° 24'	8° 44'	6° 30'	5° 14'	4° 23'	3° 47'	2° 57'	2° 25'
CM070	Z		4	3	2	2	2	1	1	1	1	1	1
	β		26° 12'	20° 15'	13° 49'	11° 15'	9° 29'	7° 0'	5° 41'	4° 46'	4° 7'	3° 13'	2° 39'

Rendimento

Efficiency

	n_1 [min ⁻¹]	Rendimento Efficiency	Rapporto / Ratio											
			5	7.5	10	15	20	25	30	40	50	60	80	100
CM026	2800	Rd	89	87	85	83	80		73	68	64	60		
		Rs	72	71	68	61	56	46	41	36	34			
CM030	2800	Rd	89	88	86	84	81	78	74	70	65	62	57	52
		Rs	72	67	63	55	50	43	39	35	31	27	23	21
CM040	2800	Rd	90	89	87	84	83	80	77	73	69	66	60	56
		Rs	74	71	67	60	55	51	45	40	36	32	28	24
CM050	2800	Rd	91	90	88	86	84	82	78	74	71	68	62	58
		Rs	73	70	66	59	55	51	44	39	35	32	27	23
CM063	2800	Rd	91	90	88	86	84	83	79	76	73	70	65	60
		Rs	73	71	67	60	55	51	45	40	36	33	28	24
CM070	2800	Rd		90	89	87	85	84	80	77	74	72	67	62
		Rs		72	69	62	60	55	48	43	38	36	31	26

Reversibilità e irreversibilità

Reversibility and irreversibility

La tabella sottostante riporta a titolo puramente indicativo i vari gradi di reversibilità/irreversibilità nei riduttori a vite senza fine in funzione del rendimento dinamico Rd e statico Rs.

The table below is provided for reference purposes only. It contains the various degrees of reversibility/irreversibility of wormgearboxes in relation to dynamic Rd and static Rs efficiency.

Rd	Reversibilità e irreversibilità dinamica	Dynamic reversibility and irreversibility
> 0.60	Reversibilità dinamica	Dynamic reversibility
0.50 - 0.60	Reversibilità dinamica incerta	Uncertain dynamic reversibility
0.40 - 0.50	Buona irreversibilità dinamica	Good dynamic irreversibility
<0.40	Irreversibilità dinamica	Dynamic irreversibility
Rs	Reversibilità e irreversibilità statica	Static reversibility and irreversibility
> 0.55	Reversibilità statica	Static reversibility
0.50 - 0.55	Reversibilità statica incerta	Uncertain static reversibility
<0.50	Irreversibilità statica	Static irreversibility

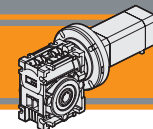

CM026 con motore brushless CC

CM026 with brushless DC motor

CM026	BLS022.240													
	24V						36V							
	n ₂ MIN			n ₂ MAX			n ₁ MAX [rpm]	n ₂ MIN			n ₂ MAX		n ₁ MAX [rpm]	
M ₂	sf		M ₂	sf		M ₂		sf		M ₂	sf			
ir	60	0.9	27	600	1.0	10	3000	80	0.9	21	800	1.0	8.0	4000
5	40	1.3	19	400	1.5	7.9		53	1.3	16	533	1.5	6.0	
7.5	30	1.7	16	300	1.9	5.8		40	1.7	12	400	1.9	4.7	
10	20	2.2	12	200	2.7	4.1		27	2.3	9.1	267	2.8	3.2	
15	15	2.8	9.3	150	3.5	3.1		20	2.9	6.9	200	3.6	2.5	
20	10	3.6	7.5	100	4.8	2.5		13	3.8	5.8	133	5.0	2.0	
30	7.5	4.4	4.8	75	6.0	1.8		10	4.6	4.1	100	6.2	1.5	
40	6	4.8	4.2	60	7.0	1.4		8.0	5.2	3.5	80	7.3	1.1	
50	5	5.4	3.3	50	7.8	1.1		6.7	5.8	2.9	67	8.2	0.9	
60														

NOTA: per servizio continuo o altamente intermittente, contattare il servizio tecnico

NOTE: for continuous or highly intermittent duty, please contact our technical service

Attenzione: superamento della coppia nominale supportata dal riduttore per servizio S1. Contattare il ns. servizio tecnico
 Attention: rated torque withstood by gear reducer for service in S1 is exceeded. Please, contact our technical office.

Tipo Type	Numero di poli Number of poles	Numero di fasi Number of phase	Tensione Rated voltage [V]	Numero di giri Rated speed [rpm]	Coppia nominale Rated torque [Nm]	Potenza nominale Rated power [W]
BLS022.240	4	3	36	4000	0.22	92
			24	3000		70
Tipo Type	Coppia massima Peak torque [Nm]	Corrente nominale Rated current [A]	Resistenza Resistance [Ω]	Induttanza Inductance [mH]	Corrente massima Peak current [A]	Peso Weight [kg]
BLS022.240	0.44	3.7	0.64	3.1	7.4	0.72

Azionamenti Drives



CM026..U
+
BLS022.240

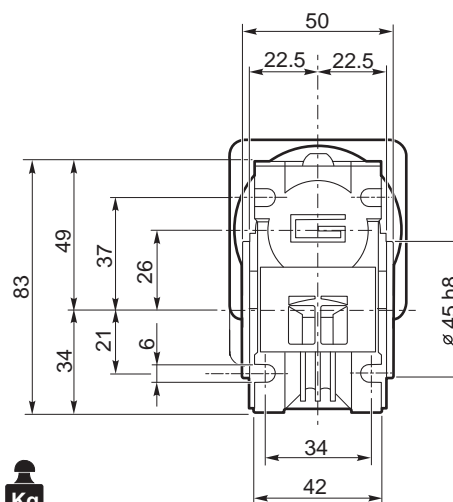
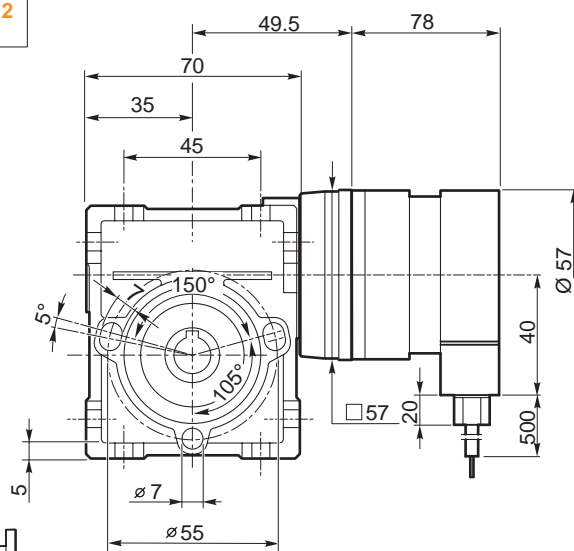

Kg
2.5

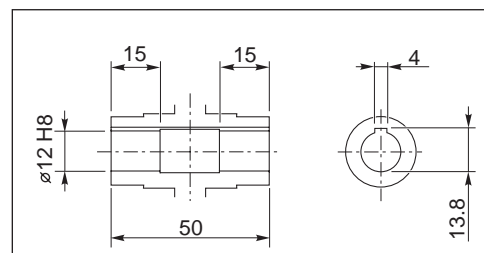

Albero lento cavo / Hollow output shaft

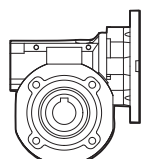

CL026

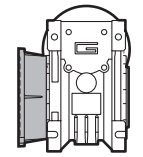

CM026.. F

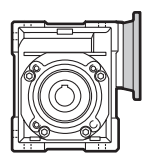

CM026.. AS...

IP 55

CM

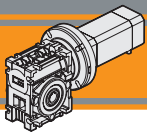

Motoriduttori brushless CC a vite senza fine Brushless DC Wormgearmotors

CM030 con motore brushless CC

CM030 with brushless DC motor

CM030	BLS043.240													
	24V							36V						
	n ₂ MIN			n ₂ MAX			n ₁ MAX [rpm]	n ₂ MIN			n ₂ MAX			n ₁ MAX [rpm]
ir	M ₂	sf	M ₂	sf	M ₂	sf		M ₂	sf	M ₂	sf	M ₂	sf	
5	60	1.7	20	600	1.9	6.8	3000	80	1.7	20	800	1.9	5.8	4000
7.5	40	2.5	14	400	2.8	5.3		53	2.5	14	533	2.8	4.6	
10	30	3.2	12	300	3.7	4.3		40	3.2	12	400	3.7	3.8	
15	20	4.4	8.6	200	5.4	3.0		26	4.4	8.6	267	5.4	2.6	
20	15	5.5	5.8	150	7.0	2.0		20	5.5	5.8	200	7.0	1.7	
25	12	6.5	4.8	120	8.4	1.8		16	6.5	4.8	160	8.4	1.5	
30	10	7.1	5.5	100	9.5	1.9		13	7.1	5.5	133	9.5	1.7	
40	7.5	8.4	3.9	75	12	1.3		10	8.4	3.9	100	12	1.2	
50	6.0	9.7	3.0	60	14	1.1		8	9.7	3.0	80	14	0.9	
60	5.0	11	2.5	50	16	0.9		6.6	11	2.5	67	16	0.8	
80	3.7	12	1.8	38	17	0.7		5	12	1.8	50	15	0.7	
100	3.0	14	1.4	30	16	0.7		4	14	1.4	40	13	0.7	

NOTA: per servizio continuo o altamente intermittente, contattare il servizio tecnico

NOTE: for continuous or highly intermittent duty, please contact our technical service

Attenzione: superamento della coppia nominale supportata dal riduttore per servizio S1. Contattare il ns. servizio tecnico
Attention: rated torque withstood by gear reducer for service in S1 is exceeded. Please, contact our technical office.

Tipo Type	Numero di poli Number of poles	Numero di fasi Number of phase	Tensione Rated voltage [V]	Numero di giri Rated speed [rpm]	Coppia nominale Rated torque [Nm]	Potenza nominale Rated power [W]
BLS043.240	4	3	36	4000	0.43	180
			24	3000		130
Tipo Type	Coppia massima Peak torque [Nm]	Corrente nominale Rated current [A]	Resistenza Resistance [Ω]	Induttanza Inductance [mH]	Corrente massima Peak current [A]	Peso Weight [kg]
BLS043.240	0.86	6.8	0.35	1	13.6	1.25

Azionamenti Drives II 2

CM030..U + BLS043.240

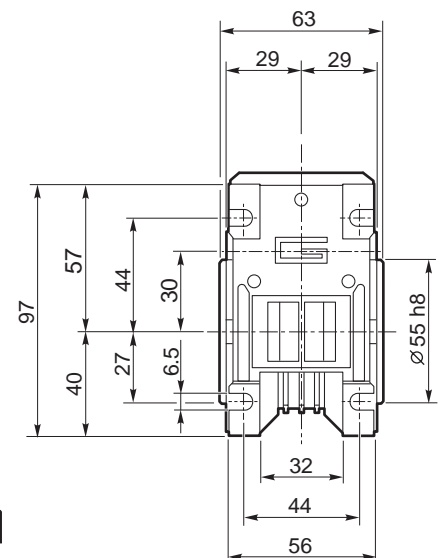
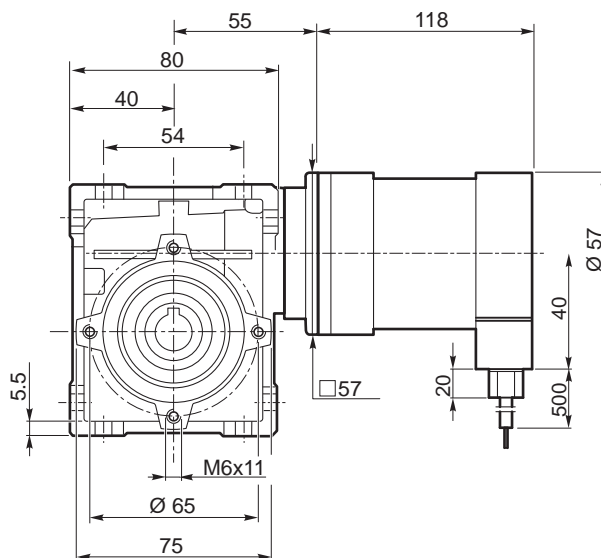

Kg
3.4

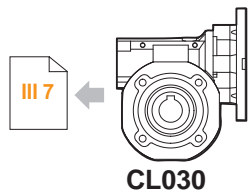

CL030

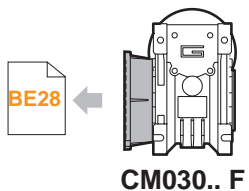

CM030.. F

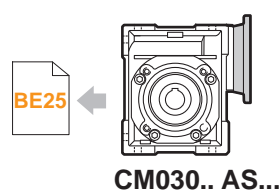

CM030.. AS...

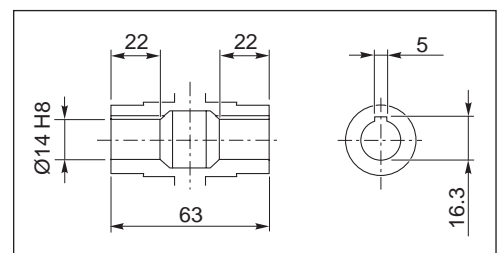

Albero lento cavo / Hollow output shaft

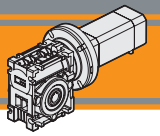

CM030 con motore brushless CC

CM030 with brushless DC motor

CM030	BL070.240 / BL070.24B / BL070.480 / BL070.48B						
	24V / 48V						
ir	n ₂ MIN			n ₂ MAX			n ₁ MAX [rpm]
		M ₂	sf		M ₂	sf	
5	60	2.8	11	600	3.1	4.2	3000
7.5	40	4.1	8.0	400	4.6	3.2	
10	30	5.3	6.4	300	6.0	2.7	
15	20	7.2	4.9	200	8.8	1.8	
20	15	9.1	3.2	150	11	1.2	
25	12	11	2.5	120	14	1.1	
30	10	12	2.9	100	16	1.2	
40	7.5	14	2.1	75	20	0.8	
50	6.0	16	1.6	60	23	0.7	

NOTA: per servizio continuo o altamente intermittente, contattare il servizio tecnico

NOTE: for continuous or highly intermittent duty, please contact our technical service

Attenzione: superamento della coppia nominale supportata dal riduttore per servizio S1. Contattare il ns. servizio tecnico
Attention: rated torque withstood by gear reducer for service in S1 is exceeded. Please, contact our technical office.

Tipo Type	Numero di poli Number of poles	Numero di fasi Number of phase	Tensione Rated voltage [V]	Numero di giri Rated speed [rpm]	Coppia nominale Rated torque [Nm]	Potenza nominale Rated power [W]
BL070.240 BL070.24B	8	3	24	3000	0.7	220
BL070.480 BL070.48B	8	3	48	3000	0.7	220
Tipo Type	Coppia massima Peak torque [Nm]	Corrente nominale Rated current [A]	Resistenza Resistance [Ω]	Induttanza Inductance [mH]	Corrente massima Peak current [A]	Peso Weight [kg]
BL070.240 BL070.24B	1.4	13	0.091	0.23	26	2.1
BL070.480 BL070.48B	1.4	6.5	0.34	1.0	13	2.1

Azionamenti Drives II 2

CM030..U
+
BL070.240
BL070.480

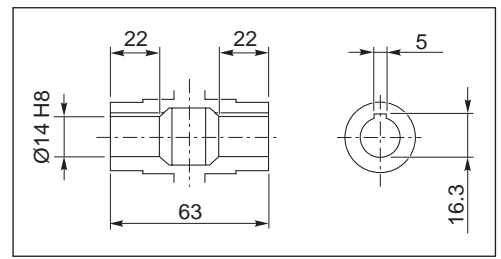
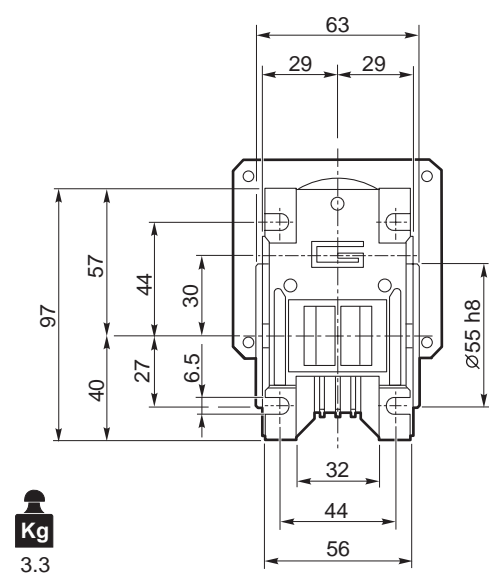
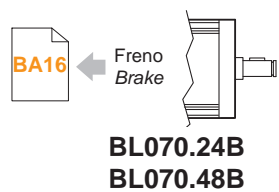
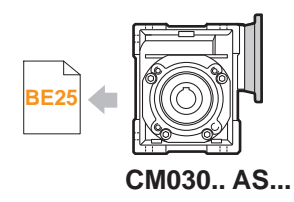
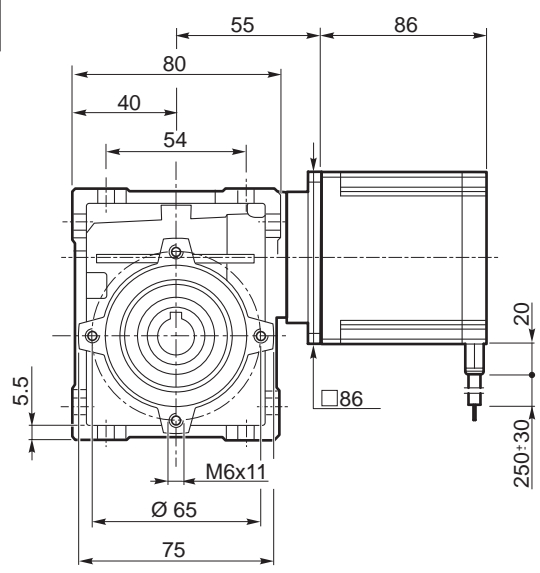
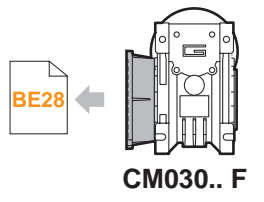
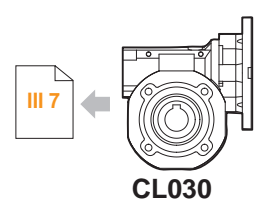

Albero lento cavo / Hollow output shaft

IP 55

CM

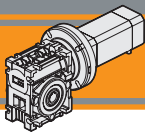

Motoriduttori brushless CC a vite senza fine

Brushless DC Wormgearmotors

CM040 con motore brushless CC

CM040 with brushless DC motor

CM030	BL070.48.80													
	24V							36V						
	ir	n ₂ MIN			n ₂ MAX			n ₁ MAX [rpm]	n ₂ MIN			n ₂ MAX		
M ₂		sf		M ₂	sf		M ₂		sf		M ₂	sf		
5	50	2.9	10.9	500	3.1	4.2	2500	80	2.9	9.3	800	3.1	3.5	4000
7.5	33	4.1	8.0	333	4.6	3.2		53	4.3	7.1	533	4.6	2.8	
10	25	5.3	6.6	250	6.0	2.7		40	5.5	5.5	400	6.0	2.3	
15	17	7.4	4.6	167	8.8	1.8		27	7.6	4.0	267	8.8	1.6	
20	13	9.1	3.3	125	11	1.2		20	9.4	2.8	200	11	1.1	
25	10	11	2.7	100	14	1.1		16	11	2.4	160	14	1.0	
30	8.3	12	3.2	83	16	1.2		13	12	2.7	133	16	1.0	
40	6.3	14	2.3	63	20	0.8		10	15	2.0	100	20	0.7	
50	5.0	16	1.8	50	21	0.7		8.0	17	1.6	80	18	0.7	
60	4.2	18	1.5	42	20	0.7		6.7	19	1.3	67	17	0.7	
80	3.1	20	1.1	31	17	0.7		5.0	21	1.0	50	14	0.7	
100	2.5	22	0.9	25	15	0.7		4.0	25	0.8	40	12	0.7	

NOTA: per servizio continuo o altamente intermittente, contattare il servizio tecnico

NOTE: for continuous or highly intermittent duty, please contact our technical service

Attenzione: superamento della coppia nominale supportata dal riduttore per servizio S1. Contattare il ns. servizio tecnico
Attention: rated torque withstood by gear reducer for service in S1 is exceeded. Please, contact our technical office.

Tipo Type	Numero di poli Number of poles	Numero di fasi Number of phase	Tensione nominale Rated voltage [V]	Velocità nominale Rated speed [rpm]	Coppia nominale Rated torque [Nm]	Potenza nominale Rated power [W]	Coppia di picco Peak torque [Nm]
BL070.48.80	8	3	48	4350	0.7	320	1.4
			24	2500		185	

Tipo Type	Corrente nominale Rated current [A]	Corrente di picco Peak current [A]	Resistenza fase-fase Line to line resistance [Ω]	Induttanza fase-fase Line to line inductance [mH]	Costante di coppia Torque constant [Nm/A]	Costante FCEM Back EMF [V/kRPM]	Inerzia rotore Rotor inertia [gcm ²]	Peso Weight [kg]
BL070.48.80	12	36	0.072	0.304	0.1	6.15	1000	1.8

Azionamenti Drives → II 2

CM030..U + BL070.48.80

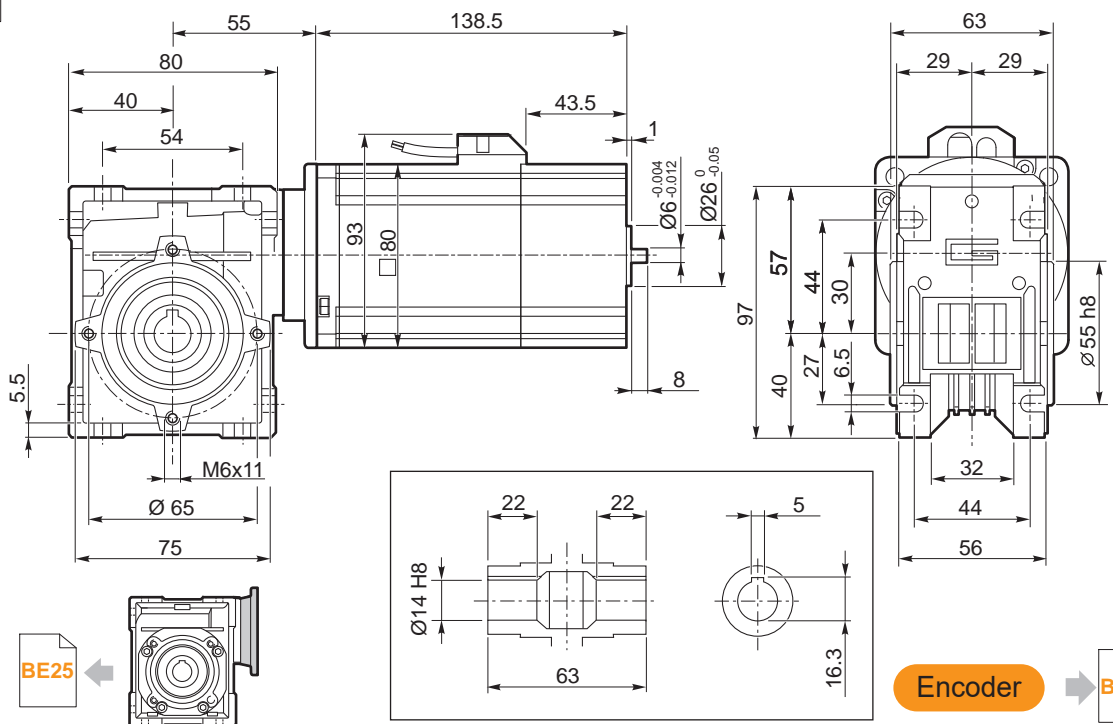
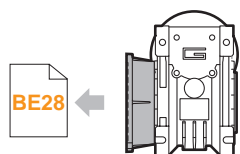
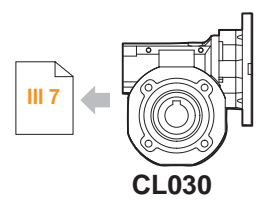

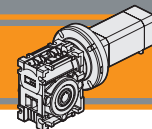

CM040 con motore brushless CC

CM040 with brushless DC motor

CM040	BLS043.240													
	24V						36V							
	n ₂ MIN			n ₂ MAX			n ₁ MAX [rpm]	n ₂ MIN			n ₂ MAX			n ₁ MAX [rpm]
M ₂	sf		M ₂	sf		M ₂		sf		M ₂	sf			
ir	60	1.8	35	600	2.0	14	3000	80	1.8	35	800	2.0	12.5	4000
5	40	2.6	26	400	2.9	11		53	2.6	26	533	2.9	9.3	
7.5	30	3.4	20	300	3.7	8.9		40	3.4	20	400	3.7	7.8	
10	20	4.6	15	200	5.4	6.5		26	4.6	15	267	5.4	5.7	
15	15	5.8	10	150	7.2	4.3		20	5.8	10	200	7.2	3.8	
20	12	6.9	7.8	120	8.6	3.2		16	6.9	7.8	160	8.6	2.8	
25	10	7.9	9.4	100	10	3.8		13	7.9	9.4	133	10	3.4	
30	7.5	9.6	6.8	75	13	2.6		10	9.6	6.8	100	13	2.3	
40	6.0	12	5.5	60	15	2.1		8	12	5.5	80	15	1.9	
50	5.0	12	4.7	50	17	1.7		6.6	12	4.7	67	17	1.5	
60	3.7	14	3.6	38	21	1.3		5	14	3.6	50	21	1.1	
80	3.0	16	2.8	30	24	1.0		4	16	2.8	40	24	0.9	
100														

NOTA: per servizio continuo o altamente intermittente, contattare il servizio tecnico

NOTE: for continuous or highly intermittent duty, please contact our technical service

Attenzione: superamento della coppia nominale supportata dal riduttore per servizio S1. Contattare il ns. servizio tecnico
Attention: rated torque withstood by gear reducer for service in S1 is exceeded. Please, contact our technical office.

Tipo Type	Numero di poli Number of poles	Numero di fasi Number of phase	Tensione Rated voltage [V]	Numero di giri Rated speed [rpm]	Coppia nominale Rated torque [Nm]	Potenza nominale Rated power [W]
BLS043.240	4	3	36	4000	0.43	180
			24	3000		130
Tipo Type	Coppia massima Peak torque [Nm]	Corrente nominale Rated current [A]	Resistenza Resistance [Ω]	Induttanza Inductance [mH]	Corrente massima Peak current [A]	Peso Weight [kg]
BLS043.240	0.86	6.8	0.35	1	13.6	1.25

Azionamenti Drives



CM040..U
+
BLS043.240

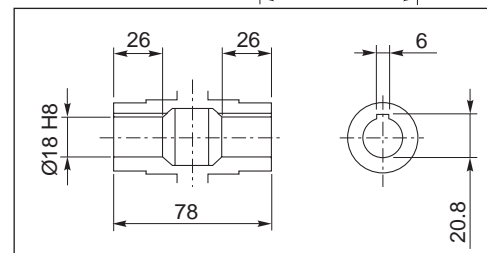
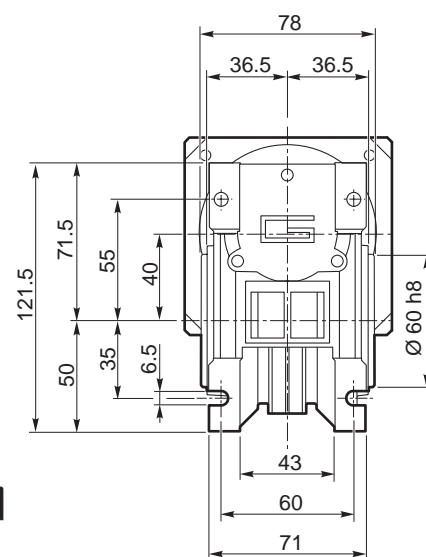
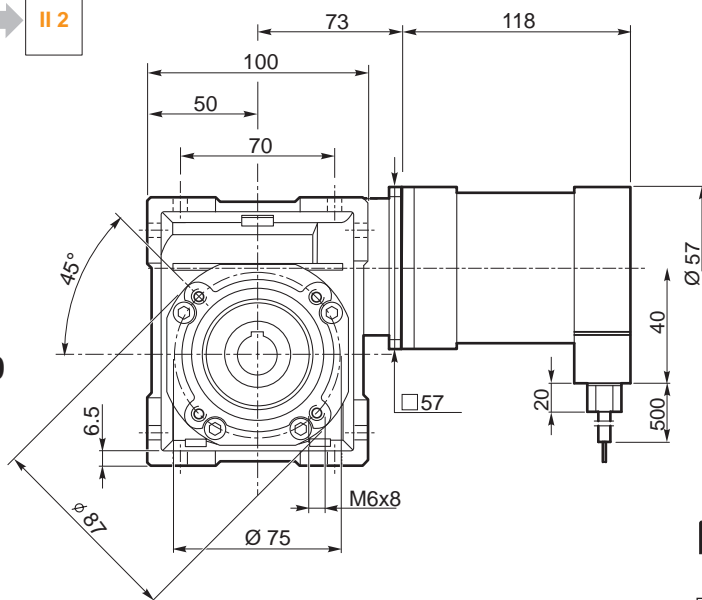

Albero lento cavo / Hollow output shaft

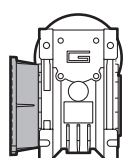

CM040.. F
CM040.. FL
CM040.. FB

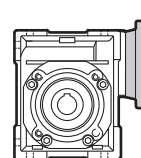

CM040.. AS...

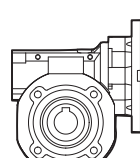

CL040

IP 55

CM

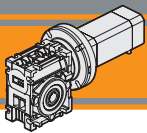

Motoriduttori brushless CC a vite senza fine Brushless DC Wormgearmotors

CM040 con motore brushless CC

CM040 with brushless DC motor

CM040	BL070.240 / BL070.24B / BL070.480 / BL070.48B						
	24V / 48V						
ir	n ₂ MIN			n ₂ MAX			n ₁ MAX [rpm]
		M ₂	sf		M ₂	sf	
5	60	2.9	25	600	3.2	9.2	3000
7.5	40	4.2	18	400	4.7	6.6	
10	30	5.3	14	300	6.1	5.4	
15	20	7.4	11	200	8.8	3.9	
20	15	9.5	7.1	150	12	2.6	
25	12	11	5.4	120	14	2.0	
30	10	12	6.7	100	16	2.3	
40	7.5	15	4.5	75	20	1.6	
50	6.0	17	3.7	60	24	1.3	
60	5.0	19	3.0	50	28	1.0	
80	3.7	22	2.2	38	34	0.8	
100	3.0	24	1.8	30	33	0.7	

NOTA: per servizio continuo o altamente intermittente, contattare il servizio tecnico

NOTE: for continuous or highly intermittent duty, please contact our technical service

Attenzione: superamento della coppia nominale supportata dal riduttore per servizio S1. Contattare il ns. servizio tecnico
Attention: rated torque withstood by gear reducer for service in S1 is exceeded. Please, contact our technical office.

Tipo Type	Numero di poli Number of poles	Numero di fasi Number of phase	Tensione Rated voltage [V]	Numero di giri Rated speed [rpm]	Coppia nominale Rated torque [Nm]	Potenza nominale Rated power [W]
BL070.240 BL070.24B	8	3	24	3000	0.7	220
BL070.480 BL070.48B	8	3	48	3000	0.7	220

Tipo Type	Coppia massima Peak torque [Nm]	Corrente nominale Rated current [A]	Resistenza Resistance [Ω]	Induttanza Inductance [mH]	Corrente massima Peak current [A]	Peso Weight [kg]
BL070.240 BL070.24B	1.4	13	0.091	0.23	26	2.1
BL070.480 BL070.48B	1.4	6.5	0.34	1.0	13	2.1

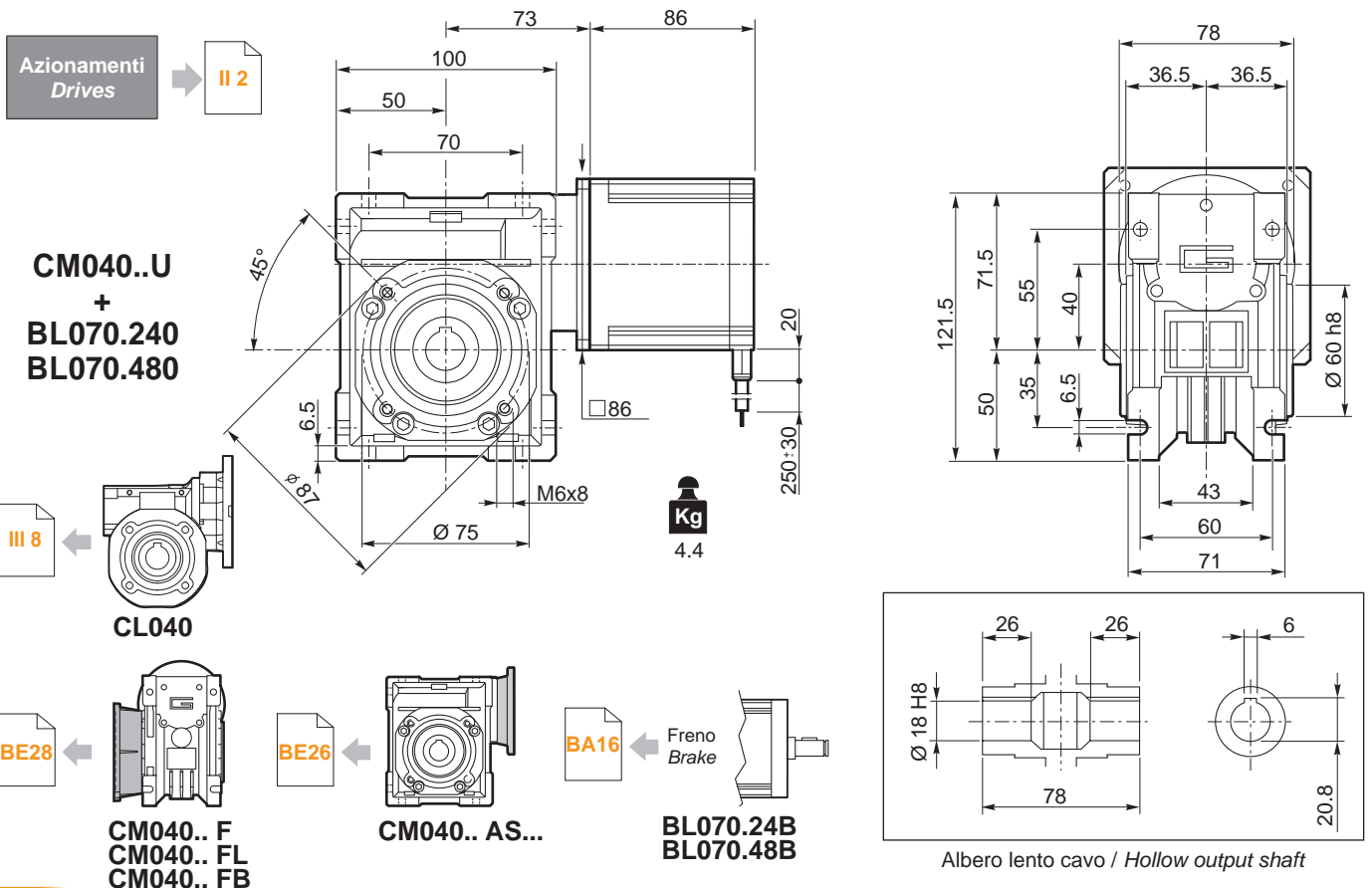

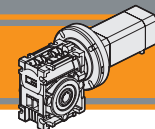

CM040 con motore brushless CC

CM040 with brushless DC motor

CM040	BL070.48.80													
	24V							36V						
	ir	n _{2MIN}		n _{2MAX}		n _{1MAX} [rpm]	n _{2MIN}		n _{2MAX}		n _{1MAX} [rpm]			
M ₂		sf	M ₂	sf	M ₂		sf	M ₂	sf					
5	50	2.9	25.6	500	3.2	9.2	2500	80	2.9	20.7	800	3.2	7.9	4000
7.5	33	4.2	17.9	333	4.7	6.6		53	4.3	15.3	533	4.7	5.8	
10	25	5.4	14.1	250	6.1	5.4		40	5.5	11.9	400	6.1	4.8	
15	17	7.5	10.2	167	8.8	4.0		27	7.7	8.6	267	8.8	3.5	
20	13	9.4	7.1	125	12	2.7		20	9.8	5.9	200	12	2.3	
25	10	11	5.6	100	14	2.0		16	12	4.4	160	14	1.7	
30	8.3	12	6.9	83	16	2.4		13	13	5.4	133	16	2.1	
40	6.3	15	4.8	63	20	1.7		10	16	3.8	100	20	1.5	
50	5.0	16	3.9	50	24	1.3		8.0	19	3.1	80	24	1.2	
60	4.2	19	3.1	42	28	1.0		6.7	21	2.6	67	28	0.9	
80	3.1	22	2.3	31	34	0.8	5.0	24	2.0	50	34	0.7		
100	2.5	24	1.9	25	34	0.7	4.0	27	1.6	40	30	0.7		

NOTA: per servizio continuo o altamente intermittente, contattare il servizio tecnico

NOTE: for continuous or highly intermittent duty, please contact our technical service

Attenzione: superamento della coppia nominale supportata dal riduttore per servizio S1. Contattare il ns. servizio tecnico
 Attention: rated torque withstood by gear reducer for service in S1 is exceeded. Please, contact our technical office.

Tipo Type	Numero di poli Number of poles	Numero di fasi Number of phase	Tensione nominale Rated voltage [V]	Velocità nominale Rated speed [rpm]	Coppia nominale Rated torque [Nm]	Potenza nominale Rated power [W]	Coppia di picco Peak torque [Nm]
BL070.48.80	8	3	48	4350	0.7	320	1.4
			24	2500		185	

Tipo Type	Corrente nominale Rated current [A]	Corrente di picco Peak current [A]	Resistenza fase-fase Line to line resistance [Ω]	Induttanza fase-fase Line to line inductance [mH]	Costante di coppia Torque constant [Nm/A]	Costante FCEM Back EMF [V/kRPM]	Inerzia rotore Rotor inertia [gcm ²]	Peso Weight [kg]
BL070.48.80	12	36	0.072	0.304	0.1	6.15	1000	1.8

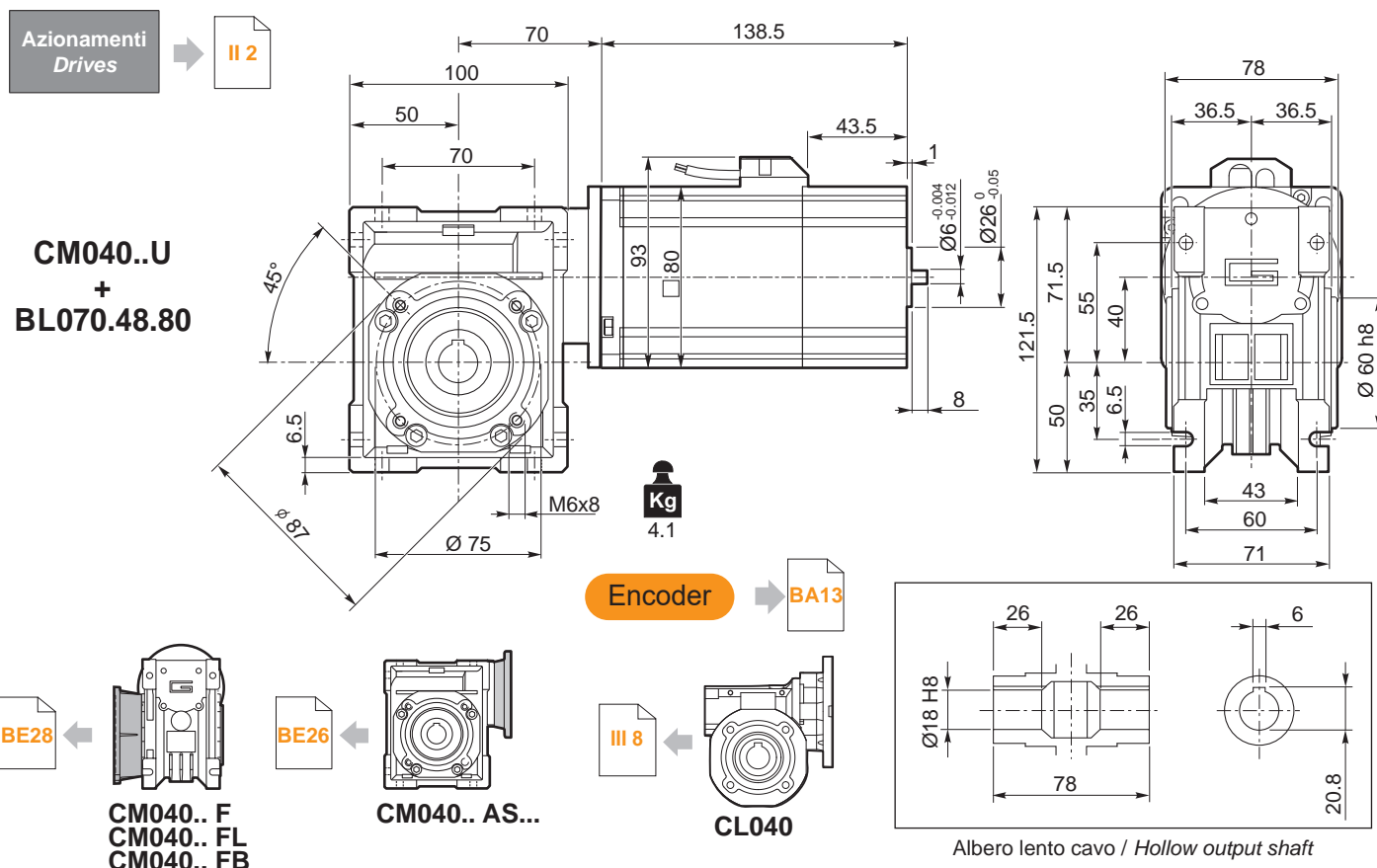

CM IP 55

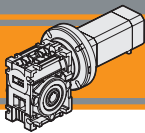

Motoriduttori brushless CC a vite senza fine Brushless DC Wormgearmotors

CM040 con motore brushless CC

CM040 with brushless DC motor

CM040	BL140.480						
	48V						
ir	n ₂ MIN			n ₂ MAX			n ₁ MAX [rpm]
		M ₂	sf		M ₂	sf	
5	60	5.8	13	600	6.3	4.6	3000
7.5	40	8.4	9.0	400	9.3	3.3	
10	30	11	7.1	300	12	2.7	
15	20	15	5.1	200	18	2.0	
20	15	19	3.6	150	23	1.3	
25	12	22	2.8	120	28	1.0	
30	10	24	3.4	100	32	1.2	
40	8	29	2.4	75	41	0.8	
50	6	33	1.9	60	41	0.7	
60	5	37	1.5	50	36	0.7	
80	4	43	1.2	38	39	0.7	
100	3	47	1.0	30	33	0.7	

NOTA: per servizio continuo o altamente intermittente, contattare il servizio tecnico

NOTE: for continuous or highly intermittent duty, please contact our technical service

Attenzione: superamento della coppia nominale supportata dal riduttore per servizio S1. Contattare il ns. servizio tecnico
Attention: rated torque withstood by gear reducer for service in S1 is exceeded. Please, contact our technical office.

Tipo Type	Numero di poli Number of poles	Numero di fasi Number of phase	Tensione Rated voltage [V]	Numero di giri Rated speed [rpm]	Coppia nominale Rated torque [Nm]	Potenza nominale Rated power [W]
BL140.480	8	3	48	3000	1.4	440
Tipo Type	Coppia massima Peak torque [Nm]	Corrente nominale Rated current [A]	Resistenza Resistance [Ω]	Induttanza Inductance [mH]	Corrente massima Peak current [A]	Peso Weight [kg]
BL140.480	2.8	13	0.16	0.5	26	3.15

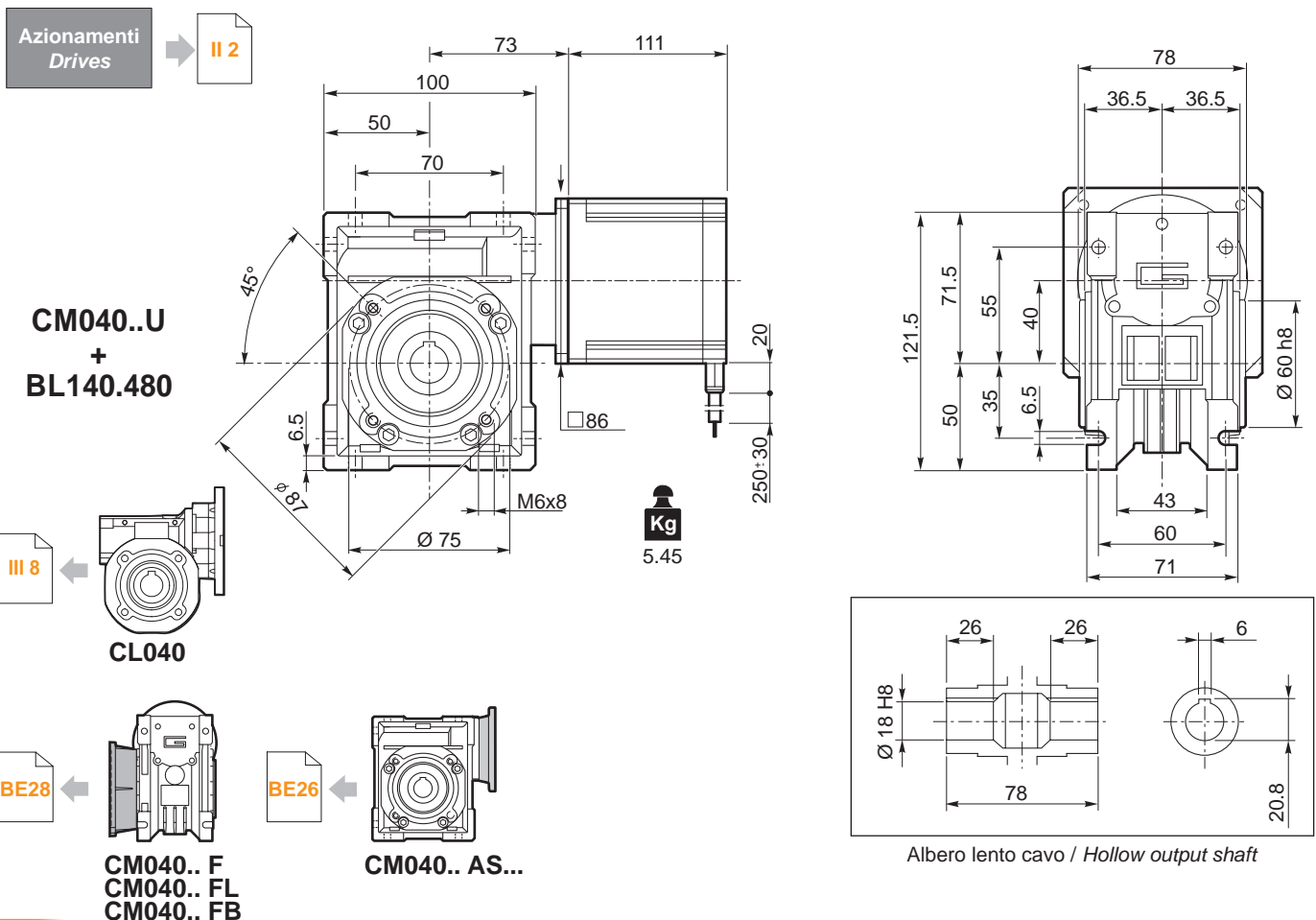

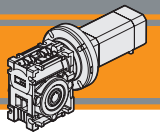

CM040 con motore brushless CC

CM040 with brushless DC motor

CM040	BL210.480 / BL210.48E						
	48V						
ir	n ₂ MIN			n ₂ MAX			n ₁ MAX [rpm]
		M ₂	sf		M ₂	sf	
5	60	8.6	8.5	600	9.4	3.1	3000
7.5	40	12	6.1	400	14	2.2	
10	30	16	4.7	300	18	1.8	
15	20	22	3.6	200	27	1.3	
20	15	29	2.3	150	35	0.9	
25	12	34	1.8	120	42	0.7	
30	10	37	2.2	100	49	0.8	
40	7.5	45	1.5	75	52	0.7	
50	6.0	50	1.2	60	41	0.7	
60	5.0	57	1.0	50	36	0.7	
80	3.7	66	0.7	38	39	0.7	
100	3.0	63	0.7	30	33	0.7	

NOTA: per servizio continuo o altamente intermittente, contattare il servizio tecnico

NOTE: for continuous or highly intermittent duty, please contact our technical service

Attenzione: superamento della coppia nominale supportata dal riduttore per servizio S1. Contattare il ns. servizio tecnico
Attention: rated torque withstood by gear reducer for service in S1 is exceeded. Please, contact our technical office.

Tipo Type	Numero di poli Number of poles	Numero di fasi Number of phase	Tensione Rated voltage [V]	Numero di giri Rated speed [rpm]	Coppia nominale Rated torque [Nm]	Potenza nominale Rated power [W]
BL210.480 BL210.48E	8	3	48	3000	2.1	660
Tipo Type	Coppia massima Peak torque [Nm]	Corrente nominale Rated current [A]	Resistenza Resistance [Ω]	Induttanza Inductance [mH]	Corrente massima Peak current [A]	Peso Weight [kg]
BL210.480 BL210.48E	4.2	18.7	0.115	0.31	37	4.2

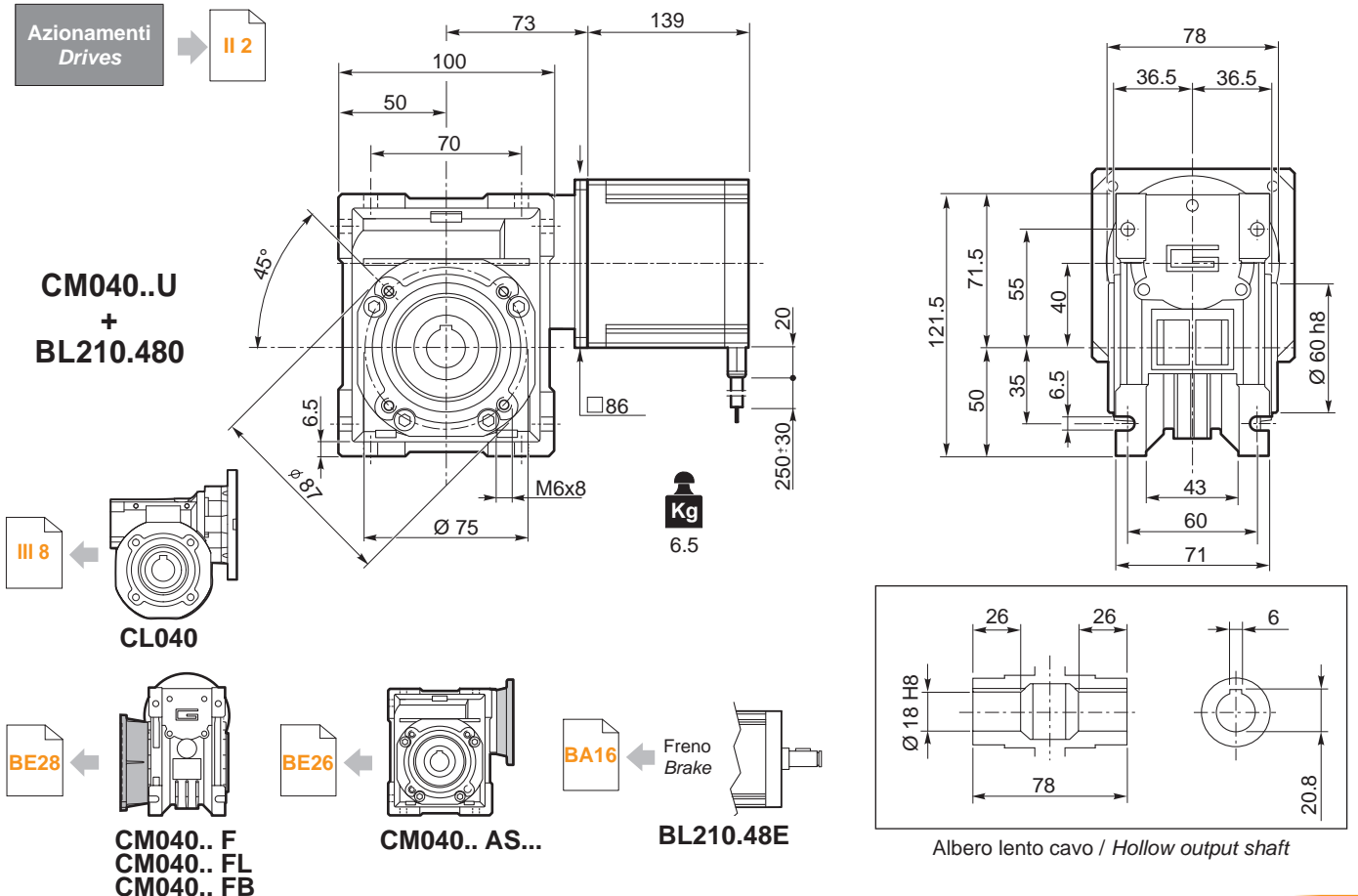

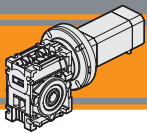

Motoriduttori brushless CC a vite senza fine Brushless DC Wormgearmotors

CM050 con motore brushless CC

CM050 with brushless DC motor

CM050	BL070.240 / BL070.24B / BL070.480 / BL070.48B						
	24V / 48V						
ir	n ₂ MIN			n ₂ MAX			n ₁ MAX [rpm]
		M ₂	sf		M ₂	sf	
5	60	3.0	46.4	600	3.3	16.0	3000
7.5	40	4.2	33.1	400	4.7	12.1	
10	30	5.4	26.2	300	6.2	9.7	
15	20	7.6	18.4	200	9.0	6.9	
20	15	9.4	13.3	150	11.8	4.7	
25	12	11	10.3	120	14.4	3.6	
30	10	12	12.4	100	16.4	4.1	
40	7.5	15	8.5	75	20.7	2.8	
50	6.0	17	7.1	60	24.9	2.3	
60	5.0	18	5.7	50	28.6	1.8	
80	3.7	21	4.3	38	34.7	1.3	
100	3.0	23	3.6	30	40.6	1.1	

NOTA: per servizio continuo o altamente intermittente, contattare il servizio tecnico

NOTE: for continuous or highly intermittent duty, please contact our technical service

Tipo Type	Numero di poli Number of poles	Numero di fasi Number of phase	Tensione Rated voltage [V]	Numero di giri Rated speed [rpm]	Coppia nominale Rated torque [Nm]	Potenza nominale Rated power [W]
BL070.240 BL070.24B	8	3	24	3000	0.7	220
BL070.480 BL070.48B	8	3	48	3000	0.7	220
Tipo Type	Coppia massima Peak torque [Nm]	Corrente nominale Rated current [A]	Resistenza Resistance [Ω]	Induttanza Inductance [mH]	Corrente massima Peak current [A]	Peso Weight [kg]
BL070.240 BL070.24B	1.4	13	0.091	0.23	26	2.1
BL070.480 BL070.48B	1.4	6.5	0.34	1.0	13	2.1

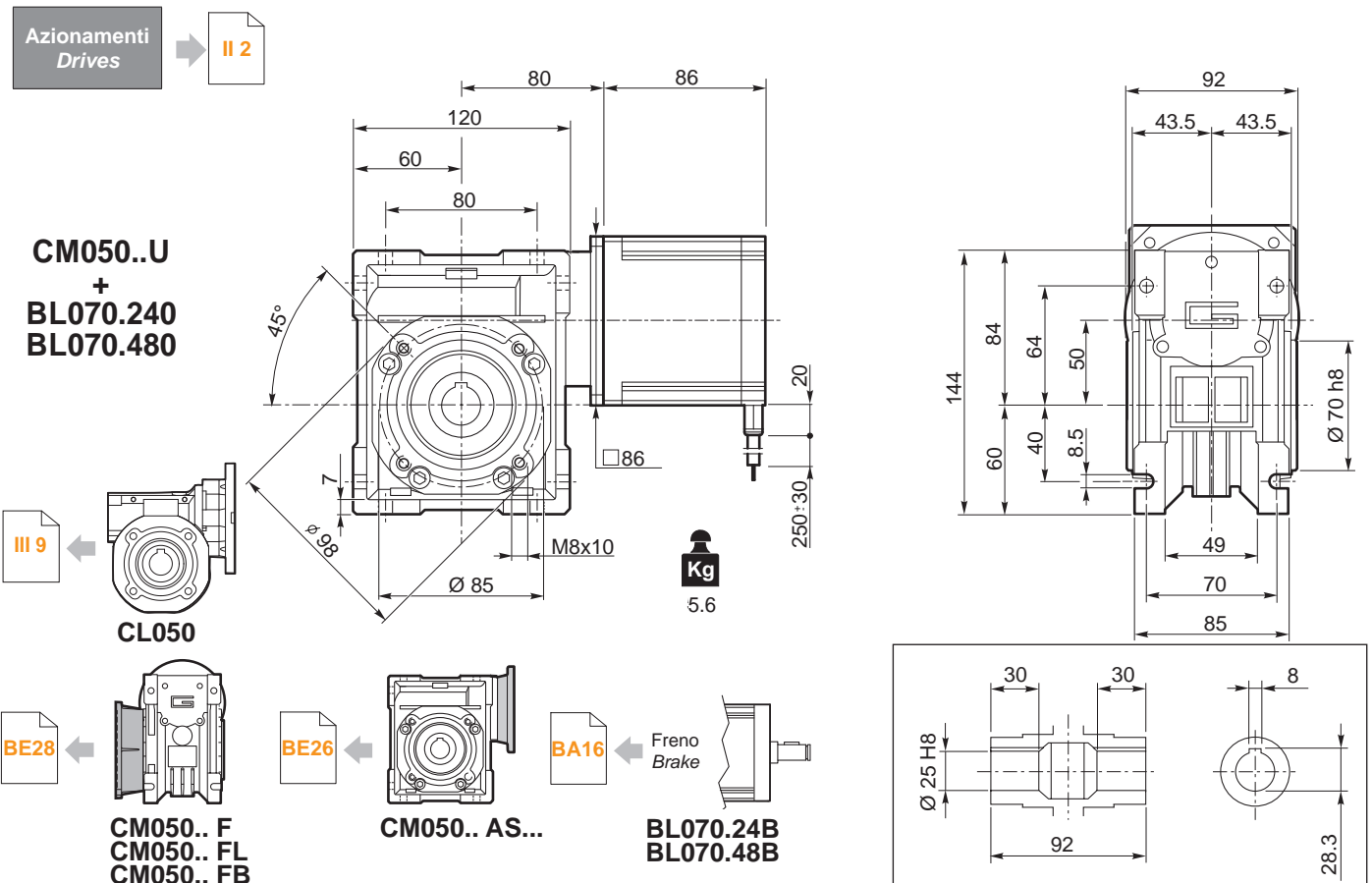

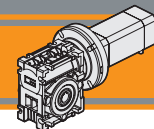

CM050 con motore brushless CC

CM050 with brushless DC motor

CM050	BL140.480						
	48V						
ir	n ₂ MIN			n ₂ MAX			n ₁ MAX [rpm]
		M ₂	sf		M ₂	sf	
5	60	5.8	24	600	6.4	8.5	3000
7.5	40	8.5	17	400	9.5	6.0	
10	30	11	13	300	12	4.9	
15	20	15	9.2	200	18	3.4	
20	15	19	6.6	150	24	2.3	
25	12	22	5.1	120	29	1.8	
30	10	24	6.2	100	33	2.0	
40	8	30	4.3	75	41	1.4	
50	6	34	3.6	60	50	1.1	
60	5	37	2.9	50	57	0.9	
80	4	43	2.1	38	66	0.7	
100	3	47	1.8	30	61	0.7	

NOTA: per servizio continuo o altamente intermittente, contattare il servizio tecnico

NOTE: for continuous or highly intermittent duty, please contact our technical service

Attenzione: superamento della coppia nominale supportata dal riduttore per servizio S1. Contattare il ns. servizio tecnico
Attention: rated torque withstood by gear reducer for service in S1 is exceeded. Please, contact our technical office.

Tipo Type	Numero di poli Number of poles	Numero di fasi Number of phase	Tensione Rated voltage [V]	Numero di giri Rated speed [rpm]	Coppia nominale Rated torque [Nm]	Potenza nominale Rated power [W]
BL140.480	8	3	48	3000	1.4	440
Tipo Type	Coppia massima Peak torque [Nm]	Corrente nominale Rated current [A]	Resistenza Resistance [Ω]	Induttanza Inductance [mH]	Corrente massima Peak current [A]	Peso Weight [kg]
BL140.480	2.8	13	0.16	0.5	26	3.15

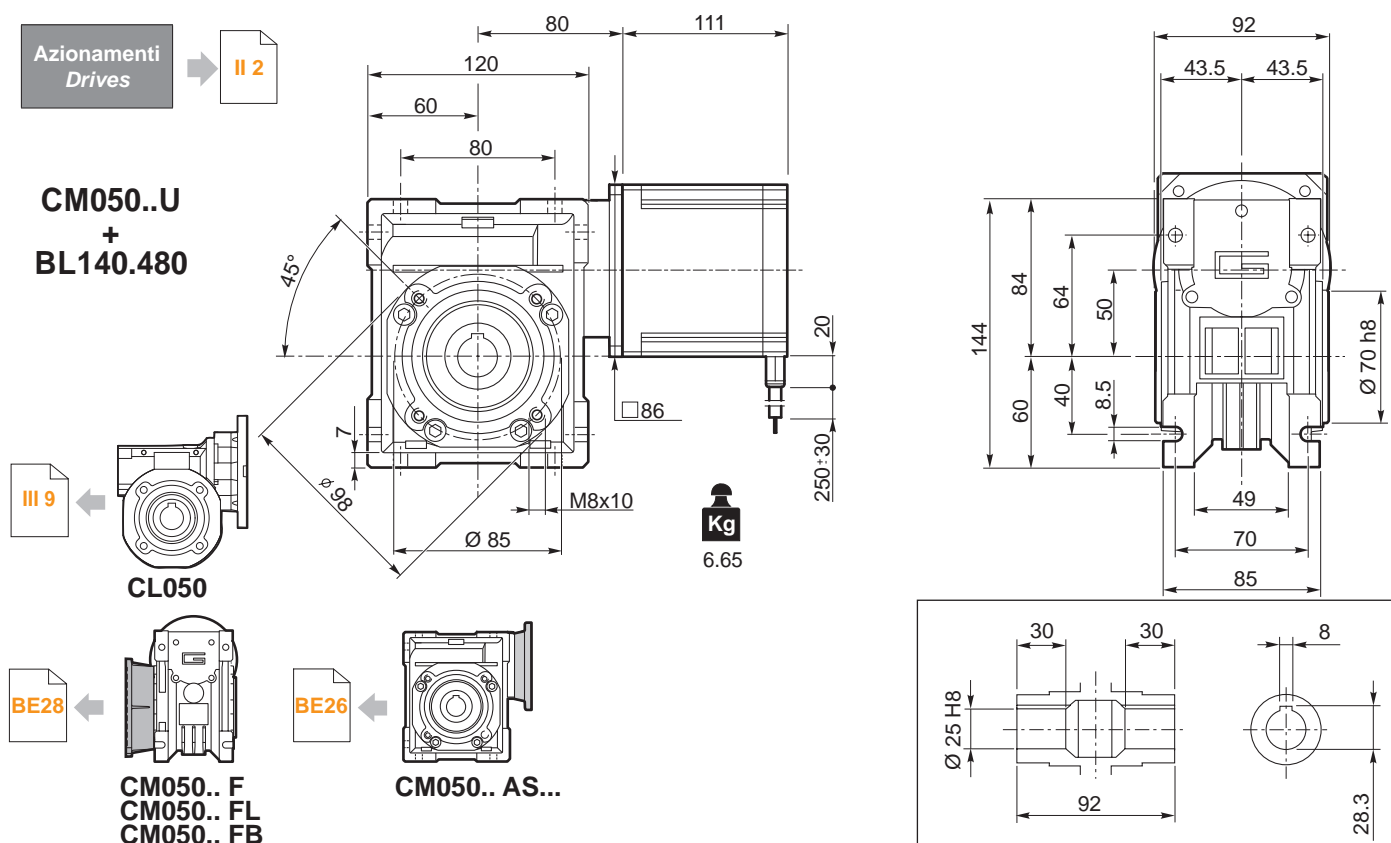

Albero lento cavo / Hollow output shaft

B-E15

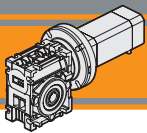

Motoriduttori brushless CC a vite senza fine

Brushless DC Wormgearmotors

CM050 con motore brushless CC

CM050 with brushless DC motor

CM050	BL200.48.95													
	24V							48V						
	ir	n ₂ MIN		n ₂ MAX		n ₁ MAX [rpm]	n ₂ MIN		n ₂ MAX		n ₁ MAX [rpm]			
M ₂		sf	M ₂	sf	M ₂		sf	M ₂	sf					
5	30	8.2	18.3	300	8.9	8.4	1500	60	8	16.3	600	9.1	5.9	3000
7.5	20	12	13.2	200	13	6.1		40	12	11.6	400	14	4.2	
10	15	15	10.2	150	17	4.8		30	15	9.2	300	18	3.4	
15	10	22	7.5	100	25	3.3		20	22	6.4	200	26	2.4	
20	7.5	27	5.0	75	32	2.3		15	27	4.7	150	34	1.6	
25	6.0	32	3.8	60	38	1.8		12	32	3.6	120	41	1.2	
30	5.0	35	4.7	50	43	2.0		10	35	4.3	100	47	1.4	
40	3.8	42	3.2	38	54	1.4		7.5	42	3.0	75	59	1.0	
50	3.0	48	2.6	30	63	1.1		6.0	48	2.5	60	71	0.8	
60	2.5	53	2.1	25	72	1.0		5.0	53	2.0	50	74	0.7	
80	1.9	61	1.6	19	85	0.7		3.8	61	1.5	38	65	0.7	

NOTA: per servizio continuo o altamente intermittente, contattare il servizio tecnico

NOTE: for continuous or highly intermittent duty, please contact our technical service

Attenzione: superamento della coppia nominale supportata dal riduttore per servizio S1. Contattare il ns. servizio tecnico
 Attention: rated torque withstood by gear reducer for service in S1 is exceeded. Please, contact our technical office.

Tipo Type	Numero di poli Number of poles	Numero di fasi Number of phase	Servizio Service	Tensione nominale Rated voltage [V]	Velocità nominale Rated speed [rpm]	Coppia nominale Rated torque [Nm]	Potenza nominale Rated power [W]	Coppia di picco Peak torque [Nm]
BL200.48.95	8	3	S1	48	3000	2.0	650	4.0
				24	1500		300	

Tipo Type	Corrente nominale Rated current [A]	Corrente di picco Peak current [A]	Resistenza fase-fase Line to line resistance [Ω]	Induttanza fase-fase Line to line inductance [mH]	Costante di coppia Torque constant [Nm/A]	Costante FCEM Back EMF [V/kRPM]	Inerzia rotore Rotor inertia [gcm ²]	Peso Weight [kg]
BL200.48.95	16.5	49.5	0.068 +/- 15%	0.25	0.091	6.7 +/- 10%	2820	6

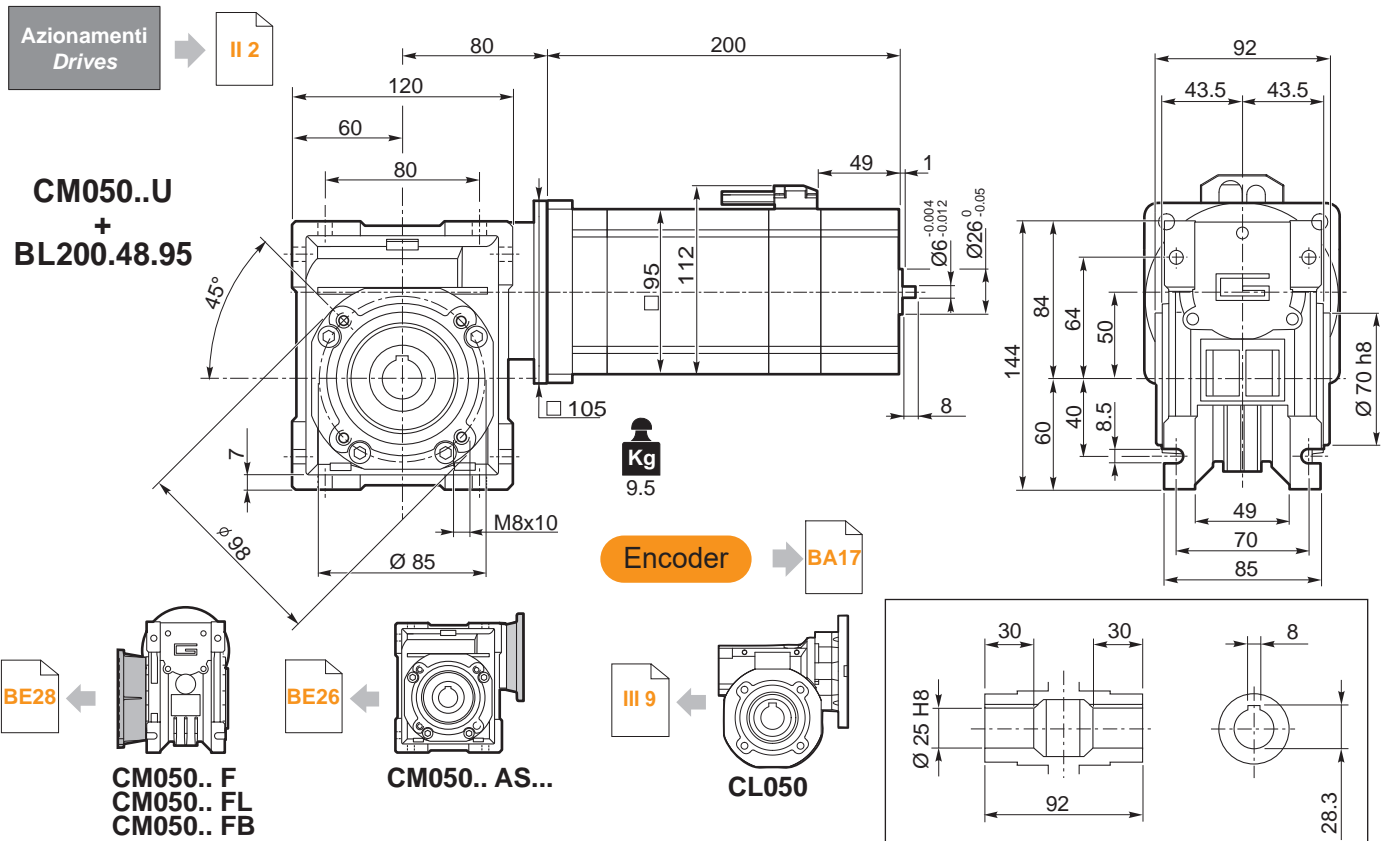

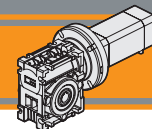

CM050 con motore brushless CC

CM050 with brushless DC motor

CM050	BL210.480 / BL210.48E						
	48V						
ir	n ₂ MIN			n ₂ MAX			n ₁ MAX [rpm]
		M ₂	sf		M ₂	sf	
5	60	8.7	16	600	9.6	5.6	3000
7.5	40	12	11	400	14	4.0	
10	30	16	8.9	300	19	3.2	
15	20	23	6.5	200	28	2.2	
20	15	29	4.5	150	35	1.6	
25	12	34	3.4	120	43	1.2	
30	10	37	4.2	100	52	1.3	
40	7.5	45	2.9	75	62	1.0	
50	6.0	50	2.4	60	75	0.8	
60	5.0	55	2.0	50	74	0.7	
80	3.7	60	1.4	38	66	0.7	
100	3.0	71	1.2	30	61	0.7	

NOTA: per servizio continuo o altamente intermittente, contattare il servizio tecnico

NOTE: for continuous or highly intermittent duty, please contact our technical service

Attenzione: superamento della coppia nominale supportata dal riduttore per servizio S1. Contattare il ns. servizio tecnico
Attention: rated torque withstood by gear reducer for service in S1 is exceeded. Please, contact our technical office.

Tipo Type	Numero di poli Number of poles	Numero di fasi Number of phase	Tensione Rated voltage [V]	Numero di giri Rated speed [rpm]	Coppia nominale Rated torque [Nm]	Potenza nominale Rated power [W]
BL210.480 BL210.48E	8	3	48	3000	2.1	660
Tipo Type	Coppia massima Peak torque [Nm]	Corrente nominale Rated current [A]	Resistenza Resistance [Ω]	Induttanza Inductance [mH]	Corrente massima Peak current [A]	Peso Weight [kg]
BL210.480 BL210.48E	4.2	18.7	0.115	0.31	37	4.2

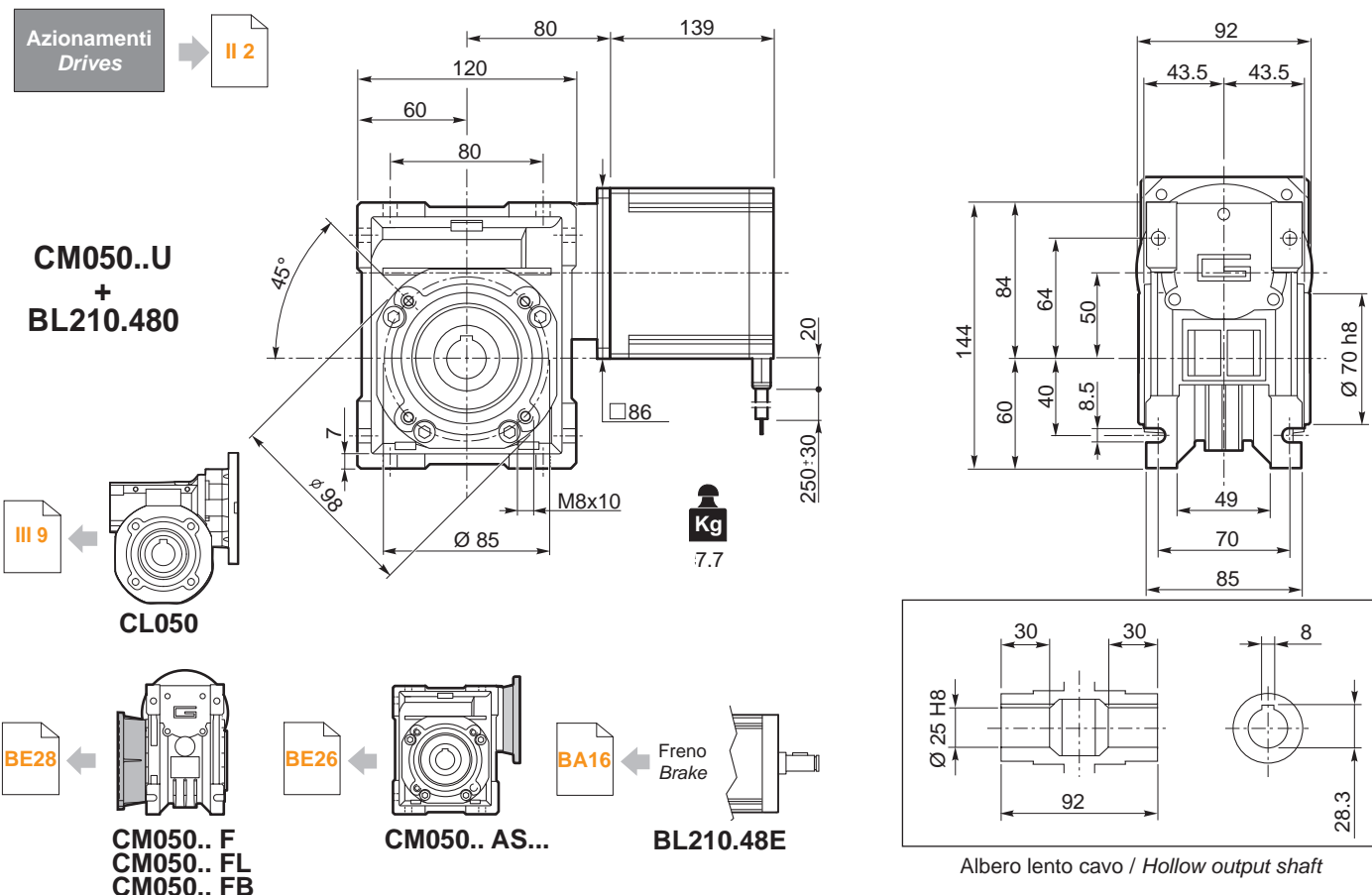

IP 55
CM

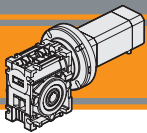

Motoriduttori brushless CC a vite senza fine Brushless DC Wormgearmotors

CM063 con motore brushless CC

CM063 with brushless DC motor

CM063	BL070.240 / BL070.24B / BL070.480 / BL070.48B						
	24V / 48V						
ir	n _{2MIN}			n _{2MAX}			n _{1MAX} [rpm]
		M ₂	sf		M ₂	sf	
40	7.5	15	15.7	75	21	5.3	3000
50	6.0	18	12.2	60	26	4.0	
60	5.0	20	10.1	50	30	3.3	
80	3.7	23	7.7	38	36	2.4	
100	3.0	25	6.3	30	42	1.9	

NOTA: per servizio continuo o altamente intermittente, contattare il servizio tecnico

NOTE: for continuous or highly intermittent duty, please contact our technical service

Tipo Type	Numero di poli Number of poles	Numero di fasi Number of phase	Tensione Rated voltage [V]	Numero di giri Rated speed [rpm]	Coppia nominale Rated torque [Nm]	Potenza nominale Rated power [W]
BL070.240 BL070.24B	8	3	24	3000	0.7	220
BL070.480 BL070.48B	8	3	48	3000	0.7	220
Tipo Type	Coppia massima Peak torque [Nm]	Corrente nominale Rated current [A]	Resistenza Resistance [Ω]	Induttanza Inductance [mH]	Corrente massima Peak current [A]	Peso Weight [kg]
BL070.240 BL070.24B	1.4	13	0.091	0.23	26	2.1
BL070.480 BL070.48B	1.4	6.5	0.34	1.0	13	2.1

Azionamenti
Drives



CM063..U
+
BL070.240
BL070.480

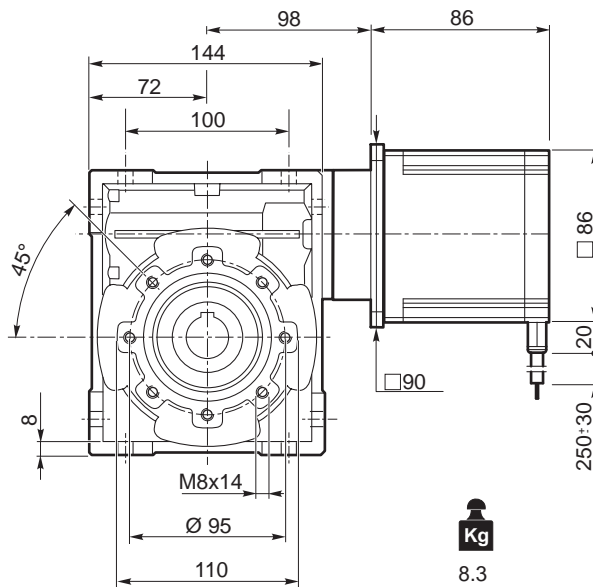

8.3

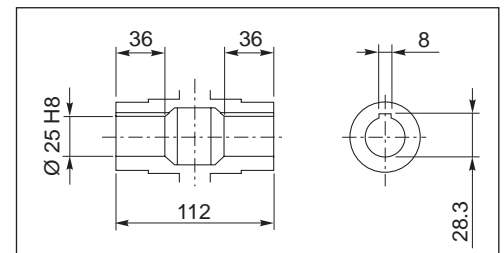
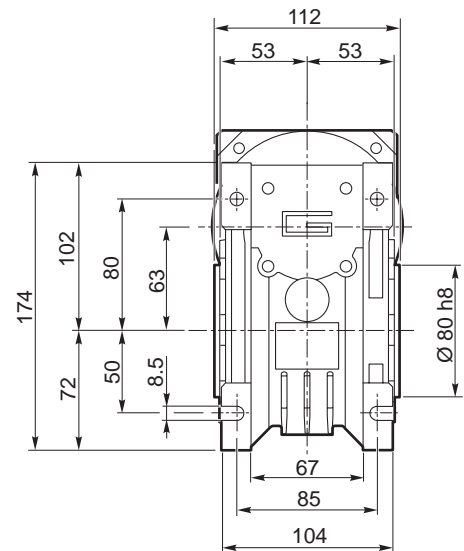

Albero lento cavo / Hollow output shaft

BE28

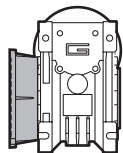

CM063.. F
CM063.. FL
CM063.. FB

BE27

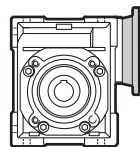

CM063.. AS...

BA16

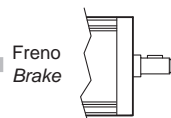

Freno
Brake
BL070.24B
BL070.48B

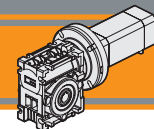

CM063 con motore brushless CC

CM063 with brushless DC motor

CM063	BL140.480						
	48V						
ir	n ₂ MIN			n ₂ MAX			n ₁ MAX [rpm]
		M ₂	sf		M ₂	sf	
40	8	31	7.9	75	43	2.6	3000
50	6	36	6.1	60	51	2.0	
60	5	40	5.1	50	59	1.6	
80	4	45	3.8	38	73	1.2	
100	3	50	3.1	30	84	1.0	

NOTA: per servizio continuo o altamente intermittente, contattare il servizio tecnico

NOTE: for continuous or highly intermittent duty, please contact our technical service

Tipo Type	Numero di poli Number of poles	Numero di fasi Number of phase	Tensione Rated voltage [V]	Numero di giri Rated speed [rpm]	Coppia nominale Rated torque [Nm]	Potenza nominale Rated power [W]
BL140.480	8	3	48	3000	1.4	440
Tipo Type	Coppia massima Peak torque [Nm]	Corrente nominale Rated current [A]	Resistenza Resistance [Ω]	Induttanza Inductance [mH]	Corrente massima Peak current [A]	Peso Weight [kg]
BL140.480	2.8	13	0.16	0.5	26	3.15

IP 55
CM

Azionamenti Drives

II 2

CM063..U
+
BL140.480

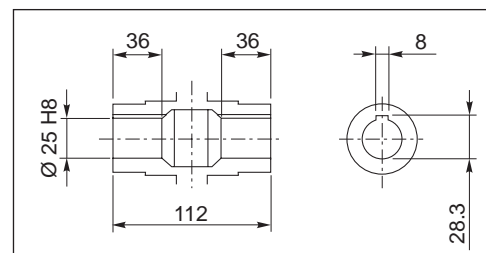
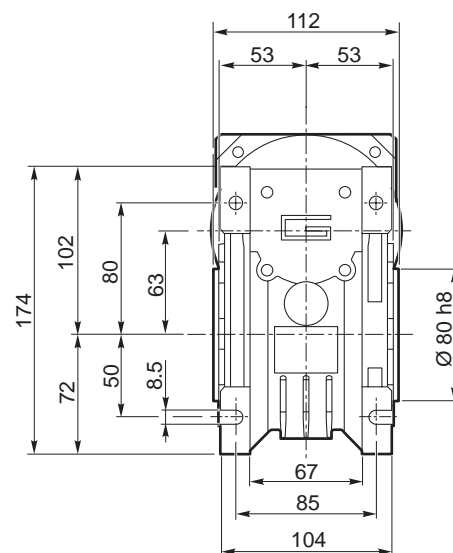
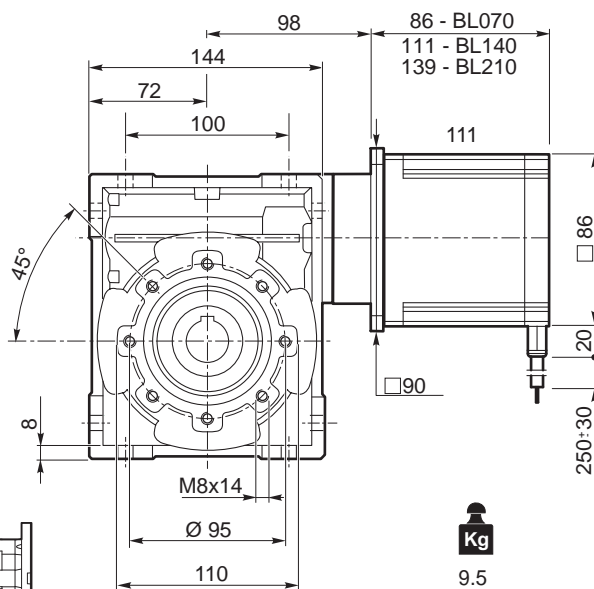

Albero lento cavo / Hollow output shaft

III 10

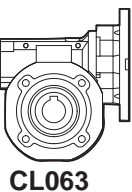

BE28

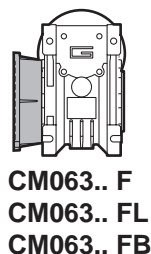

BE27

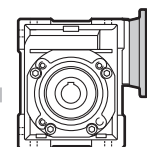

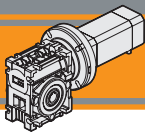

Motoriduttori brushless CC a vite senza fine Brushless DC Wormgearmotors

CM063 con motore brushless CC

CM063 with brushless DC motor

CM063	BL200.48.95													
	24V							48V						
	ir	n _{2MIN}		n _{2MAX}		n _{1MAX} [rpm]	n _{2MIN}		n _{2MAX}		n _{1MAX} [rpm]			
M ₂		sf	M ₂	sf	M ₂		sf	M ₂	sf					
5	30	8.2	33.8	300	9.0	14.9	1500	60	8.4	28.2	600	9.1	10.7	3000
7.5	20	12	24.3	200	13	10.9		40	12	20.9	400	14	7.6	
10	15	15	18.6	150	17	8.6		30	16	16.6	300	18	6.3	
15	10	21	14.2	100	25	6.1		20	22	12.0	200	26	4.5	
20	7.5	27	9.7	75	32	4.2		15	28	8.3	150	34	3.0	
25	6.0	32	7.3	60	39	3.5		12	33	6.5	120	42	2.3	
30	5.0	36	8.6	50	45	3.7		10	36	7.8	100	47	2.7	
40	3.8	43	6.0	38	56	2.5		7.5	44	5.5	75	61	1.8	
50	3.0	50	4.6	30	66	2.1		6.0	51	4.3	60	73	1.4	
60	2.5	55	3.9	25	76	1.7		5.0	56	3.5	50	84	1.2	
80	1.9	64	2.9	19	91	1.3	3.8	65	2.7	38	104	0.8		
100	1.5	70	2.3	15	104	1.1	3.0	71	2.2	30	114	0.7		

NOTA: per servizio continuo o altamente intermittente, contattare il servizio tecnico

NOTE: for continuous or highly intermittent duty, please contact our technical service

Attenzione: superamento della coppia nominale supportata dal riduttore per servizio S1. Contattare il ns. servizio tecnico
Attention: rated torque withstood by gear reducer for service in S1 is exceeded. Please, contact our technical office.

Tipo Type	Numero di poli Number of poles	Numero di fasi Number of phase	Servizio Service	Tensione nominale Rated voltage [V]	Velocità nominale Rated speed [rpm]	Coppia nominale Rated torque [Nm]	Potenza nominale Rated power [W]	Coppia di picco Peak torque [Nm]
BL200.48.95	8	3	S1	48	3000	2.0	650	4.0
				24	1500		300	

Tipo Type	Corrente nominale Rated current [A]	Corrente di picco Peak current [A]	Resistenza fase-fase Line to line resistance [Ω]	Induttanza fase-fase Line to line inductance [mH]	Costante di coppia Torque constant [Nm/A]	Costante FCME Back EMF [V/kRPM]	Inerzia rotore Rotor inertia [gcm ²]	Peso Weight [kg]
BL200.48.95	16.5	49.5	0.068 +/- 15%	0.25	0.091	6.7 +/- 10%	2820	6

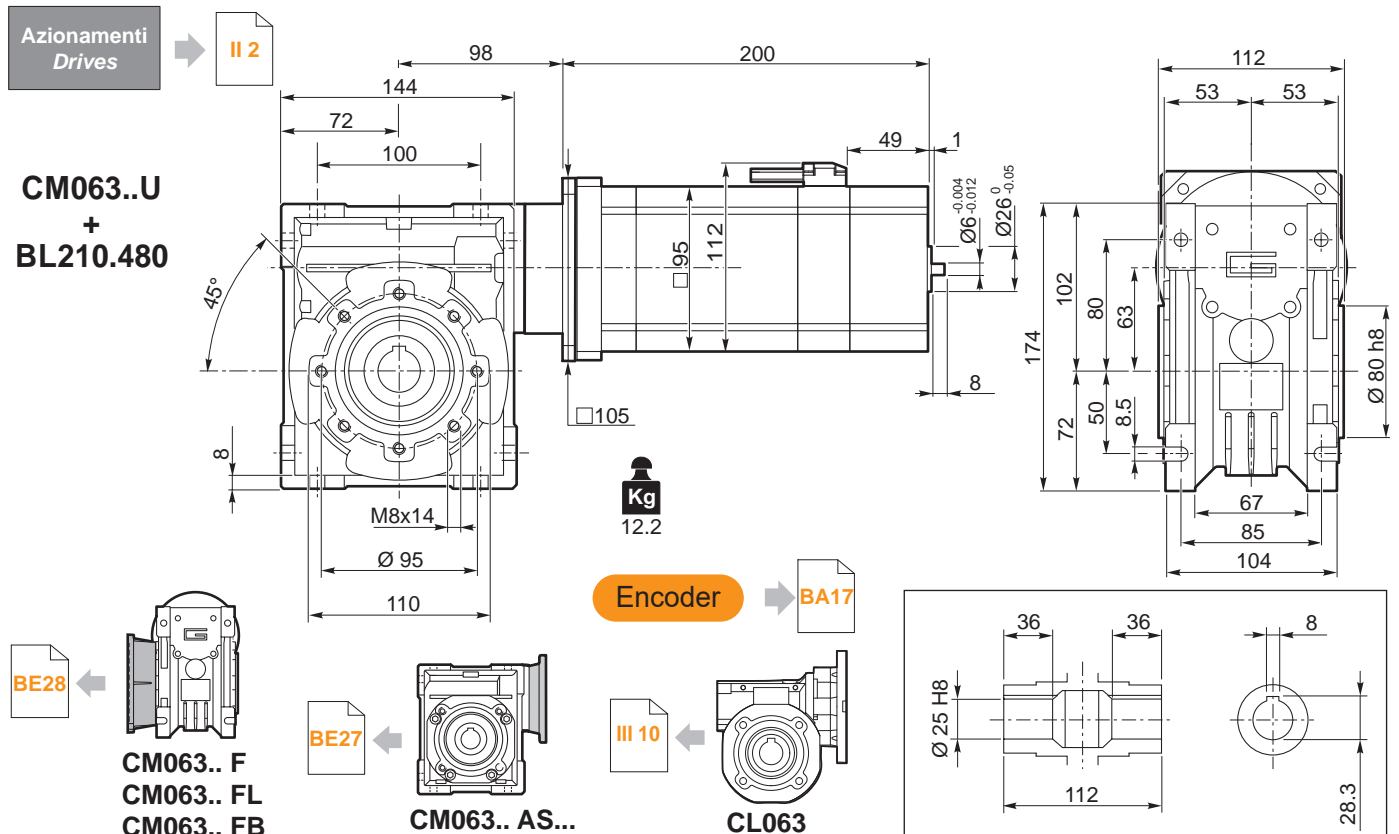

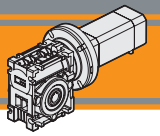

CM063 con motore brushless CC

CM063 with brushless DC motor

CM063	BL210.480 / BL210.48E						
	48V						
ir	n ₂ MIN			n ₂ MAX			n ₁ MAX [rpm]
		M ₂	sf		M ₂	sf	
40	7.5	46	5.2	75	64	1.8	3000
50	6.0	53	4.1	60	77	1.3	
60	5.0	59	3.4	50	88	1.1	
80	3.7	68	2.6	38	109	0.8	
100	3.0	75	2.1	30	114	0.7	

NOTA: per servizio continuo o altamente intermittente, contattare il servizio tecnico

NOTE: for continuous or highly intermittent duty, please contact our technical service

Attenzione: superamento della coppia nominale supportata dal riduttore per servizio S1. Contattare il ns. servizio tecnico
Attention: rated torque withstood by gear reducer for service in S1 is exceeded. Please, contact our technical office.

Tipo Type	Numero di poli Number of poles	Numero di fasi Number of phase	Tensione Rated voltage [V]	Numero di giri Rated speed [rpm]	Coppia nominale Rated torque [Nm]	Potenza nominale Rated power [W]
BL210.480 BL210.48E	8	3	48	3000	2.1	660
Tipo Type	Coppia massima Peak torque [Nm]	Corrente nominale Rated current [A]	Resistenza Resistance [Ω]	Induttanza Inductance [mH]	Corrente massima Peak current [A]	Peso Weight [kg]
BL210.480 BL210.48E	4.2	18.7	0.115	0.31	37	4.2

Azionamenti Drives



CM063..U
+
BL210.480

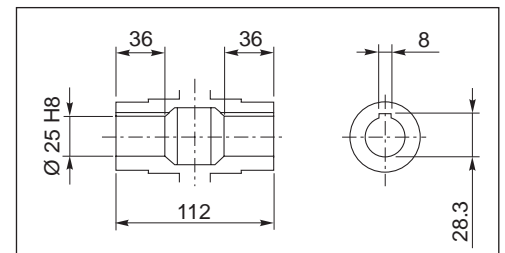
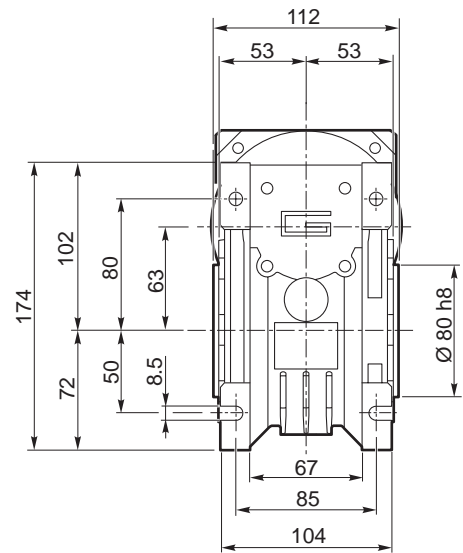
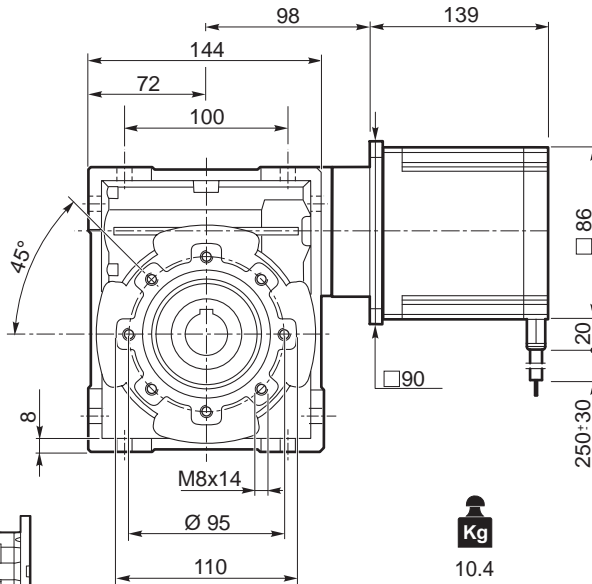

Albero lento cavo / Hollow output shaft

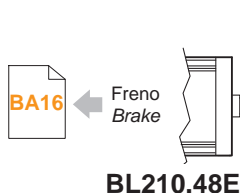
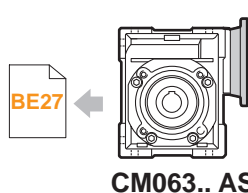
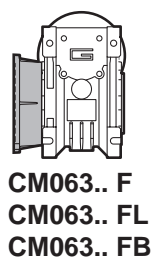
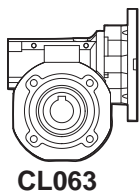

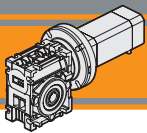

Motoriduttori brushless CC a vite senza fine Brushless DC Wormgearmotors

CM063 con motore brushless CC

CM063 with brushless DC motor

CM063	BL400.48.120													
	24V							48V						
	ir	n ₂ MIN		sf	n ₂ MAX		n ₁ MAX [rpm]	n ₂ MIN		sf	n ₂ MAX		n ₁ MAX [rpm]	
M ₂		M ₂	M ₂		M ₂	M ₂		M ₂						
5	28	14	19.3	280	16	8.5	1400	60	15	16.1	600	16	6.1	3000
7.5	19	21	13.9	187	23	6.2		40	21	12.0	400	24	4.4	
10	14	27	10.6	140	30	4.9		30	28	9.5	300	31	3.6	
15	9	37	8.1	93	44	3.5		20	38	6.9	200	45	2.5	
20	7.0	47	5.5	70	57	2.4		15	48	4.8	150	59	1.7	
25	5.6	55	4.2	56	68	2.0		12	57	3.7	120	73	1.3	
30	4.7	63	4.9	47	79	2.1		10	64	4.4	100	83	1.5	
40	3.5	76	3.4	35	98	1.4		7.5	77	3.1	75	106	1.1	
50	2.8	88	2.7	28	116	1.2		6.0	89	2.4	60	128	0.8	
60	2.3	97	2.2	23	132	1.0		5.0	99	2.0	50	138	0.7	

NOTA: per servizio continuo o altamente intermittente, contattare il servizio tecnico

NOTE: for continuous or highly intermittent duty, please contact our technical service

Attenzione: superamento della coppia nominale supportata dal riduttore per servizio S1. Contattare il ns. servizio tecnico
Attention: rated torque withstood by gear reducer for service in S1 is exceeded. Please, contact our technical office.

Tipo Type	Numero di poli Number of poles	Numero di fasi Number of phase	Servizio Service	Tensione nominale Rated voltage [V]	Velocità nominale Rated speed [rpm]	Coppia nominale Rated torque [Nm]	Potenza nominale Rated power [W]	Coppia di picco Peak torque [Nm]	Corrente nominale Rated current [A]	Corrente di picco Peak current [A]
BL400.48.120	8	3	S3	48	3000	4.2	1320	8.4	33	99
			S1			3.5	1100	7.0	28	84
			S3	24	1400	4.2	615	8.4	33	99
			S1			3.5	515	7.0	28	84

Tipo Type	Resistenza fase-fase Line to line resistance [Ω]	Induttanza fase-fase Line to line inductance [mH]	Costante di coppia Torque constant [Nm/A]	Costante FCEM Back EMF [V/kRPM]	Inerzia rotore Rotor inertia [gcm ²]	Peso Weight [kg]
BL400.48.120	0.064	0.31	0.120	12.6	21380	11

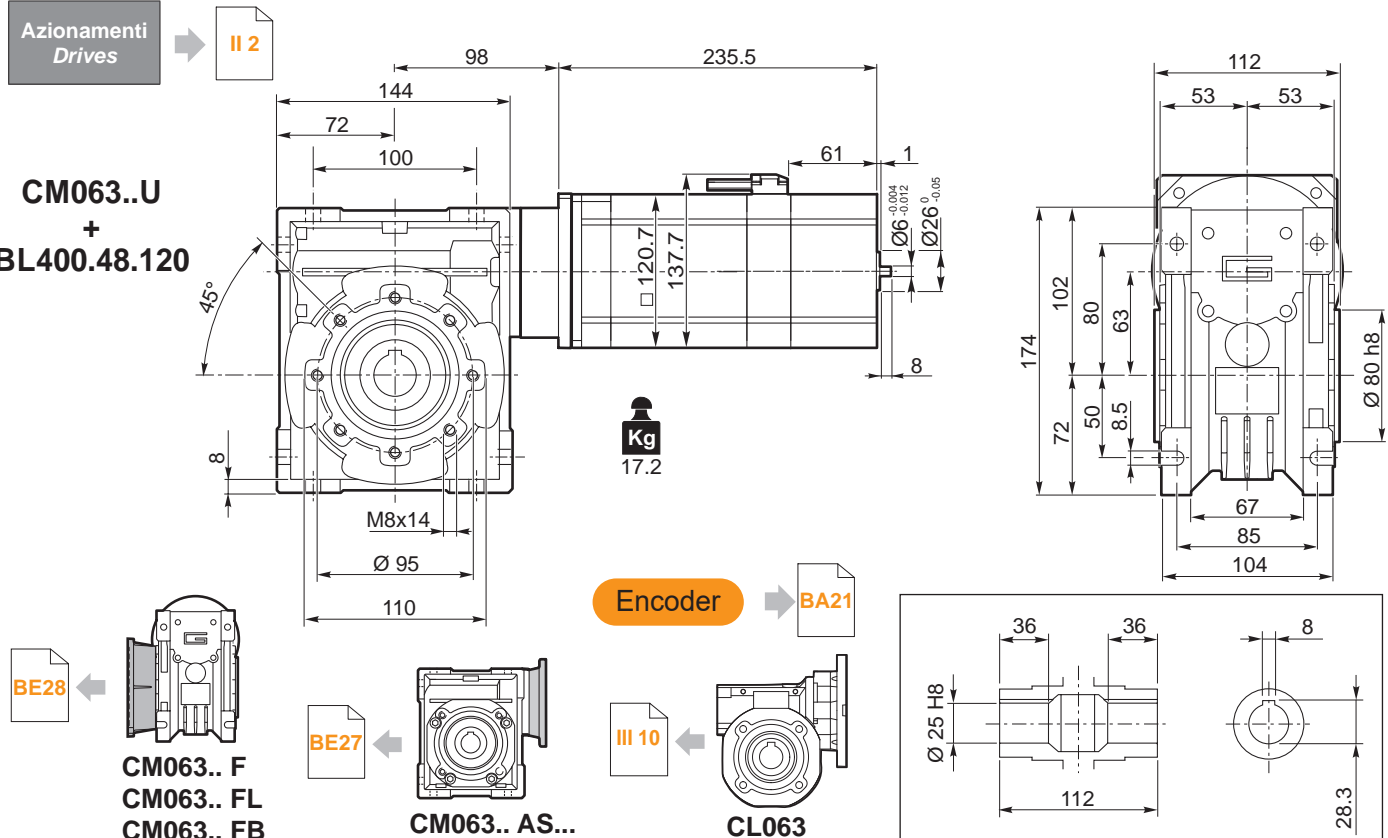

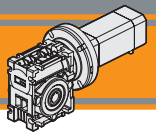

CM070 con motore brushless CC

CM063 with brushless DC motor

CM070	BL400.48.120													
	24V							48V						
	ir	n ₂ MIN		sf	n ₂ MAX		n ₁ MAX [rpm]	n ₂ MIN		sf	n ₂ MAX		n ₁ MAX [rpm]	
M ₂		M ₂	M ₂		M ₂	M ₂		M ₂	M ₂					
7.5	19	21	18.9	187	23	8.5	1400	40	22	16.2	400	24	6.0	3000
10	14	27	15.4	140	31	7.1		30	28	13.4	300	31	5.0	
15	9	38	11.6	93	44	5.0		20	39	9.6	200	46	3.6	
20	7.0	48	8.2	70	57	3.5		15	50	6.9	150	60	2.6	
25	5.6	57	6.0	56	70	2.6		12	59	5.3	120	73	1.9	
30	4.7	62	7.2	47	80	3.0		10	66	6.3	100	84	2.2	
40	3.5	75	5.0	35	101	2.1		7.5	79	4.5	75	108	1.5	
50	2.8	87	3.8	28	119	1.6		6.0	92	3.4	60	129	1.2	
60	2.3	97	3.3	23	137	1.3		5.0	103	2.9	50	151	0.9	
80	1.8	113	2.4	18	167	1.0		3.8	121	2.1	38	180	0.7	
100	1.4	124	1.9	14	186	0.8		3.0	134	1.7	30	165	0.7	

NOTA: per servizio continuo o altamente intermittente, contattare il servizio tecnico

NOTE: for continuous or highly intermittent duty, please contact our technical service

Attenzione: superamento della coppia nominale supportata dal riduttore per servizio S1. Contattare il ns. servizio tecnico
Attention: rated torque withstood by gear reducer for service in S1 is exceeded. Please, contact our technical office.

Tipo Type	Numero di poli Number of poles	Numero di fasi Number of phase	Servizio Service	Tensione nominale Rated voltage [V]	Velocità nominale Rated speed [rpm]	Coppia nominale Rated torque [Nm]	Potenza nominale Rated power [W]	Coppia di picco Peak torque [Nm]	Corrente nominale Rated current [A]	Corrente di picco Peak current [A]
BL400.48.120	8	3	S3	48	3000	4.2	1320	8.4	33	99
			S1			3.5	1100	7.0	28	84
			S3	24	1400	4.2	615	8.4	33	99
			S1			3.5	515	7.0	28	84

Tipo Type	Resistenza fase-fase Line to line resistance [Ω]	Induttanza fase-fase Line to line inductance [mH]	Costante di coppia Torque constant [Nm/A]	Costante FCEM Back EMF [V/kRPM]	Inerzia rotore Rotor inertia [gcm ²]	Peso Weight [kg]
BL400.48.120	0.064	0.31	0.120	12.6	21380	11

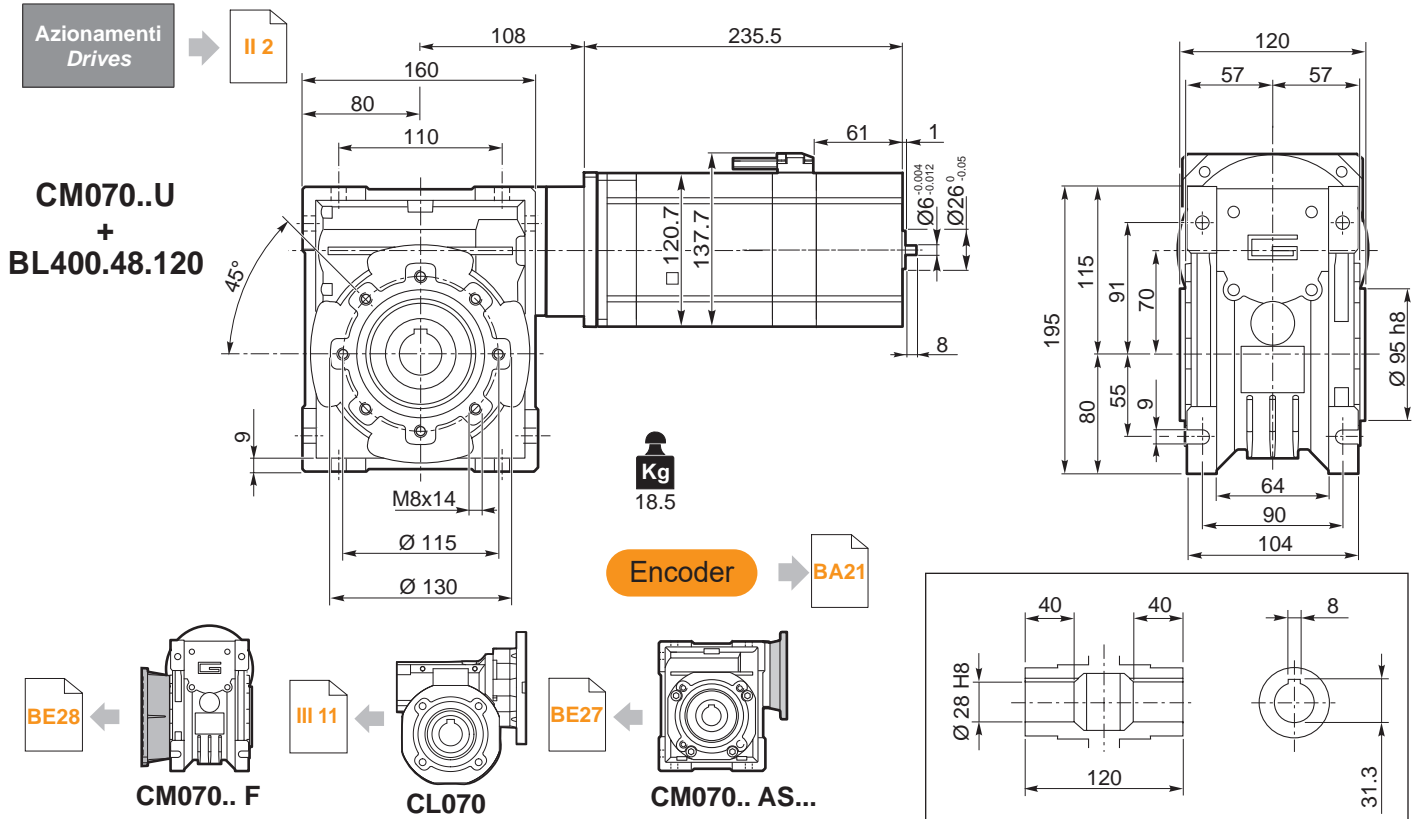

Albero lento cavo / Hollow output shaft

IP 55
CM

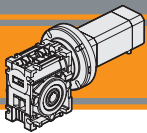



Motoriduttori brushless CC a vite senza fine

Brushless DC Wormgearmotors

Dati tecnici

Technical data

	n_2 [min ⁻¹]	Mn_2 [Nm]	Pn_1 [kW]	i
CM026				
$n_1 = 1400$ rpm	280	13	0.44	5
	187	14	0.33	7.5
	140	14	0.25	10
	93	14	0.18	15
	70	14	0.14	20
	47	15	0.11	30
	35	14	0.08	40
	28	13	0.07	50
	23	12	0.06	60

	n_2 [min ⁻¹]	Mn_2 [Nm]	Pn_1 [kW]	i
CM030				
$n_1 = 1400$ rpm	280	18	0.61	5
	187	20	0.46	7.5
	140	21	0.37	10
	93	21	0.26	15
	70	19	0.19	20
	56	20	0.16	25
	47	22	0.16	30
	35	20	0.12	40
	28	19	0.10	50
	23	17	0.08	60
	18	15	0.06	80
	14	14	0.05	100

	n_2 [min ⁻¹]	Mn_2 [Nm]	Pn_1 [kW]	i
CM040				
$n_1 = 1400$ rpm	280	41	1.37	5
	187	44	1.00	7.5
	140	45	0.79	10
	93	45	0.54	15
	70	40	0.38	20
	56	38	0.30	25
	47	48	0.34	30
	35	42	0.24	40
	28	39	0.19	50
	23	36	0.15	60
	18	33	0.12	80
	14	31	0.10	100

	n_2 [min ⁻¹]	Mn_2 [Nm]	Pn_1 [kW]	i
CM050				
$n_1 = 1400$ rpm	280	75	2.5	5
	187	79	1.8	7.5
	140	82	1.4	10
	93	82	0.98	15
	70	72	0.67	20
	56	70	0.54	25
	47	88	0.60	30
	35	76	0.42	40
	28	72	0.34	50
	23	69	0.28	60
	18	60	0.20	80
	14	56	0.17	100

	n_2 [min ⁻¹]	Mn_2 [Nm]	Pn_1 [kW]	i
CM063				
$n_1 = 1400$ rpm	280	134	4.4	5
	187	144	3.2	7.5
	140	148	2.5	10
	93	154	1.8	15
	70	136	1.23	20
	56	135	1.0	25
	47	166	1.1	30
	35	142	0.74	40
	28	136	0.60	50
	23	126	0.49	60
	18	118	0.38	80
	14	116	0.33	100

	n_2 [min ⁻¹]	Mn_2 [Nm]	Pn_1 [kW]	i
CM070				
$n_1 = 1400$ rpm	187	200	4.4	7.5
	140	218	3.7	10
	93	221	2.6	15
	70	202	1.8	20
	56	180	1.3	25
	47	241	1.6	30
	35	210	1.1	40
	28	190	0.82	50
	23	181	0.68	60
	18	159	0.49	80
	14	154	0.43	100

	n_2 [min ⁻¹]	Mn_2 [Nm]	Pn_1 [kW]	i
CM026				
$n_1 = 3000$ rpm	600	10	0.71	5
	400	11	0.53	7.5
	300	11	0.41	10
	200	11	0.28	15
	150	11	0.22	20
	100	12	0.17	30
	75	11	0.13	40
	60	10	0.10	50
	50	9	0.08	60

	n_2 [min ⁻¹]	Mn_2 [Nm]	Pn_1 [kW]	i
CM030				
$n_1 = 3000$ rpm	600	13	0.92	5
	400	15	0.71	7.5
	300	16	0.58	10
	200	16	0.40	15
	150	14	0.27	20
	120	15	0.24	25
	100	18	0.25	30
	75	16	0.18	40
	60	15	0.14	50
	50	14	0.12	60
	37.5	12	0.08	80
	30	11	0.07	100

	n_2 [min ⁻¹]	Mn_2 [Nm]	Pn_1 [kW]	i
CM040				
$n_1 = 3000$ rpm	600	29	2.02	5
	400	31	1.46	7.5
	300	33	1.19	10
	200	35	0.87	15
	150	31	0.59	20
	120	28	0.44	25
	100	38	0.52	30
	75	34	0.37	40
	60	32	0.29	50
	50	29	0.23	60
	37.5	27	0.18	80
	30	24	0.13	100

	n_2 [min ⁻¹]	Mn_2 [Nm]	Pn_1 [kW]	i
CM050				
$n_1 = 3000$ rpm	600	54	3.73	5
	400	57	2.65	7.5
	300	60	2.14	10
	200	62	1.51	15
	150	55	1.03	20
	120	51	0.78	25
	100	67	0.90	30
	75	59	0.63	40
	60	57	0.50	50
	50	52	0.40	60
	37.5	46	0.29	80
	30	43	0.23	100

	n_2 [min ⁻¹]	Mn_2 [Nm]	Pn_1 [kW]	i
CM063				
$n_1 = 3000$ rpm	600	97	6.70	5
	400	103	4.79	7.5
	300	110	3.93	10
	200	115	2.80	15
	150	102	1.91	20
	120	94	1.42	25
	100	127	1.68	30
	75	112	1.16	40
	60	103	0.89	50
	50	97	0.73	60
	37.5	87	0.53	80
	30	80	0.42	100

	n_2 [min ⁻¹]	Mn_2 [Nm]	Pn_1 [kW]	i
CM070				
$n_1 = 1400$ rpm	400	142	6.6	7.5
	300	157	5.5	10
	200	166	4.0	15
	150	153	2.8	20
	120	137	2.0	25
	100	186	2.4	30
	75	166	1.7	40
	60	150	1.3	50
	50	142	1.0	60
	38	126	0.74	80
	30	116	0.59	100

NOTA: per servizio continuo o altamente intermittente, contattare il servizio tecnico

NOTE: for continuous or highly intermittent duty, please contact our technical service

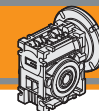

Dimensioni CM con flange motore AS

CM dimensions with motor flanges AS

CM026 - U - AS...

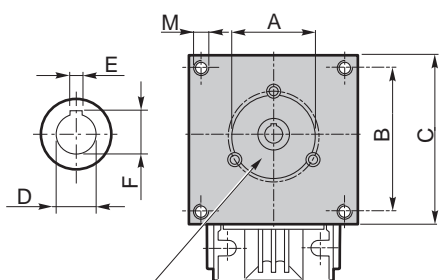

Connessione con boccola o giunto in funzione del diametro dell'albero motore.

Connection with sleeve or coupling depending on motorshaft's diameter.

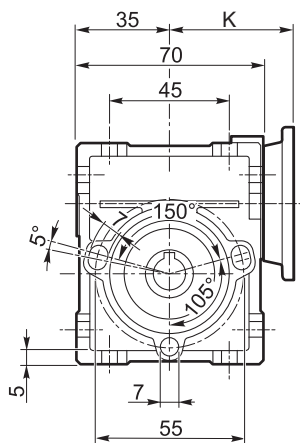

Lo spessore della flangia è variabile in funzione delle diverse lunghezze dell'albero motore.

Flange's thickness may vary depending on motorshaft's lenght.

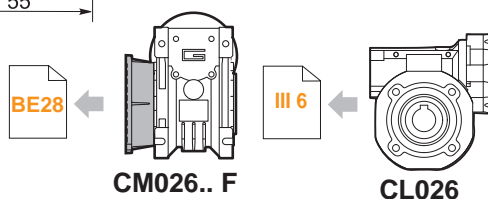
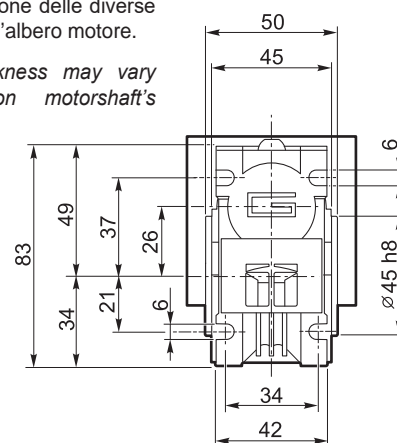

Kg
0.8

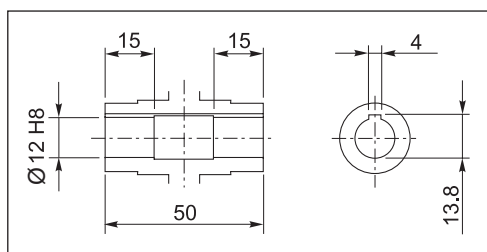

Albero lento cavo / Hollow output shaft

Dimensioni / Dimensions						Rapporti / Ratio		
AS	A	B	C	M	K	5...100		
						D	E	F
AS417	38.1	47.1	56	M4	49.5	9	3	10.4
...

CM030 - U - AS...

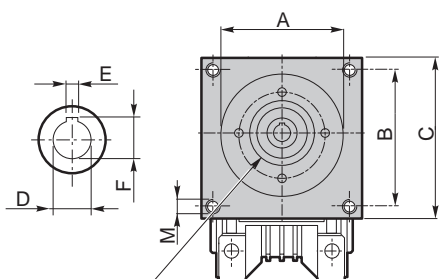

Connessione con boccola o giunto in funzione del diametro dell'albero motore.

Connection with sleeve or coupling depending on motorshaft's diameter.

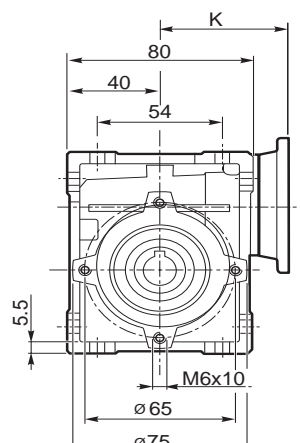

Lo spessore della flangia è variabile in funzione delle diverse lunghezze dell'albero motore.

Flange's thickness may vary depending on motorshaft's lenght.

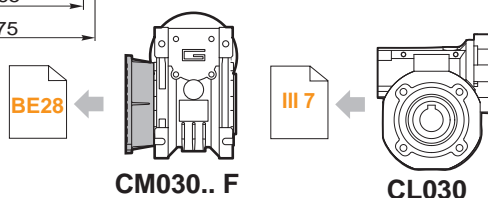
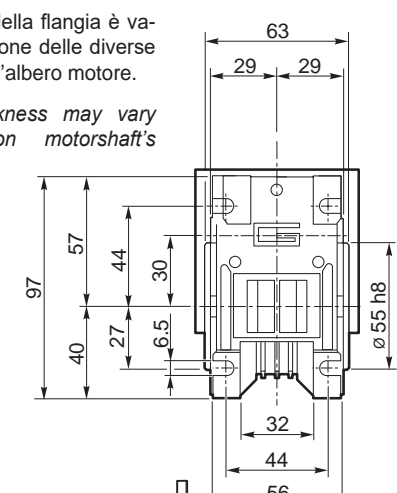

Kg
1.2

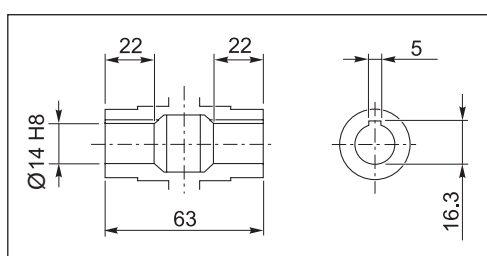

Albero lento cavo / Hollow output shaft

Dimensioni / Dimensions						Rapporti / Ratio					
AS	A	B	C	M	K	5...50			60...100		
						D	E	F	D	E	F
AS393	38.1	47.1	57	M5	55	11	4	12.8	9	3	10.4
AS391	73	69.6	86	M5	55	11	4	12.8	9	3	10.4
...

IP 55

CM

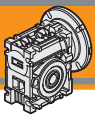

CM

Riduttori a vite senza fine
Wormgearboxes

Dimensioni CM con flange motore AS

CM dimensions with motor flanges AS

CM040 - U - AS...

Lo spessore della flangia è variabile in funzione delle diverse lunghezze dell'albero motore.

Flange's thickness may vary depending on motorshaft's length.

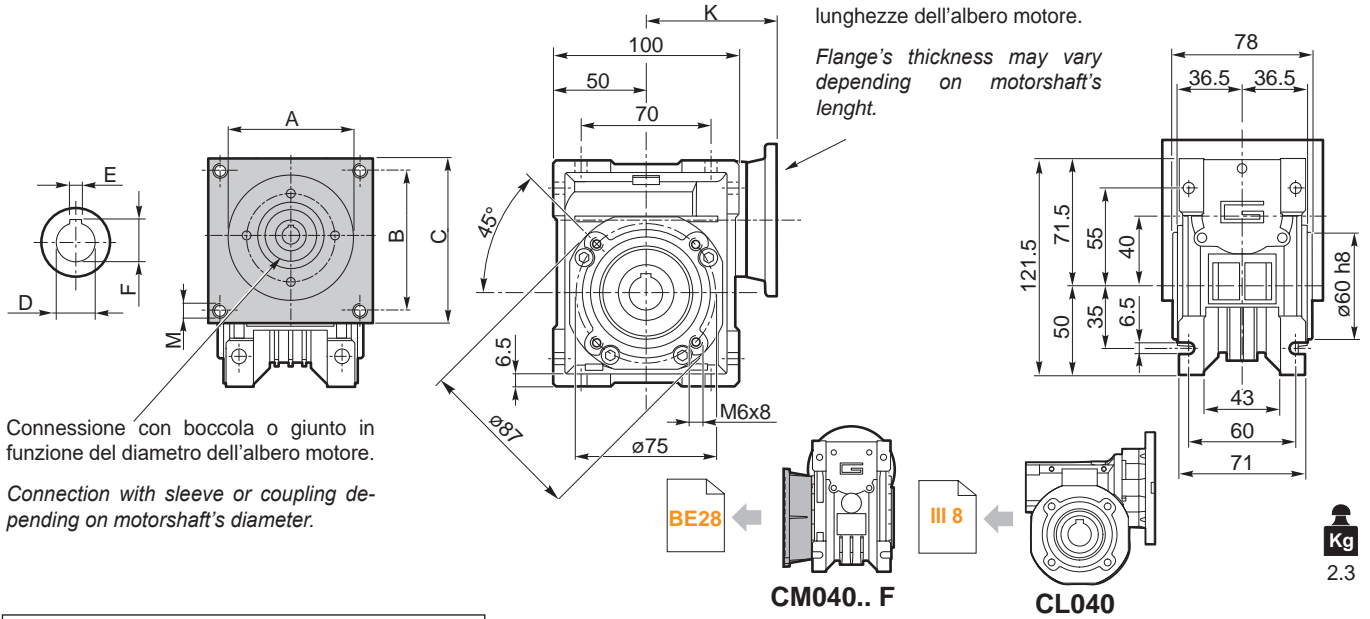

Connessione con boccola o giunto in funzione del diametro dell'albero motore.

Connection with sleeve or coupling depending on motorshaft's diameter.

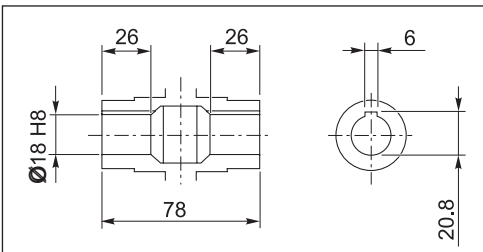

Albero lento cavo / Hollow output shaft

Dimensioni / Dimensions											
AS	A	B	C	M	K	Rapporti / Ratio					
						5...40			50...100		
						D	E	F	D	E	F
AS392FX	38.1	47.1	64	M5	73	14	5	16.3	11	4	12.8
AS384FX	73	69.6	86	M5	73	14	5	16.3	11	4	12.8
...

CM050 - U - AS...

Lo spessore della flangia è variabile in funzione delle diverse lunghezze dell'albero motore.

Flange's thickness may vary depending on motorshaft's length.

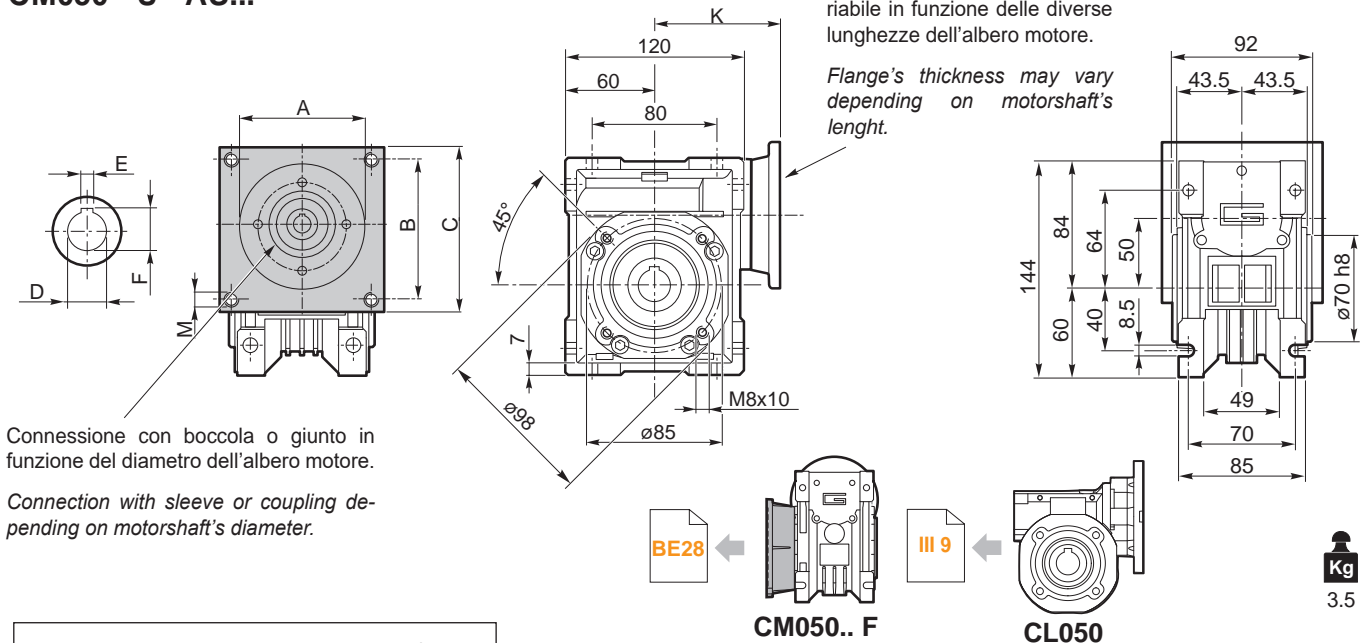

Connessione con boccola o giunto in funzione del diametro dell'albero motore.

Connection with sleeve or coupling depending on motorshaft's diameter.

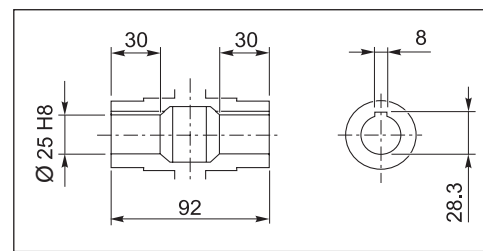

Albero lento cavo / Hollow output shaft

Dimensioni / Dimensions														
AS	A	B	C	M	K	Rapporti / Ratio								
						5...30			40...80		100			
						D	E	F	D	E	F	D	E	F
AS363	73	69.5	86	M5	80	19	6	21.8	14	5	16.3	11	4	12.8
...

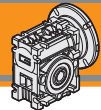

Dimensioni CM con flange motore AS

CM dimensions with motor flanges AS

CM063 - U - AS...

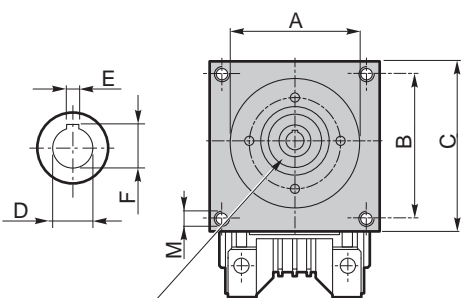

Connessione con boccola o giunto in funzione del diametro dell'albero motore.

Connection with sleeve or coupling depending on motorshaft's diameter.

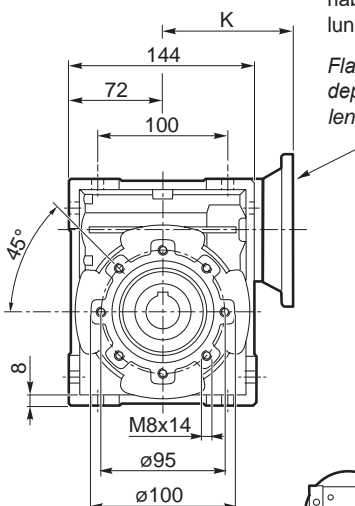

Lo spessore della flangia è variabile in funzione delle diverse lunghezze dell'albero motore.

Flange's thickness may vary depending on motorshaft's length.

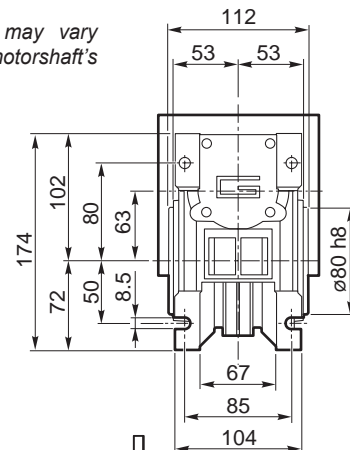

BE28

III 10

Kg
6.2

CM063.. F

CL063

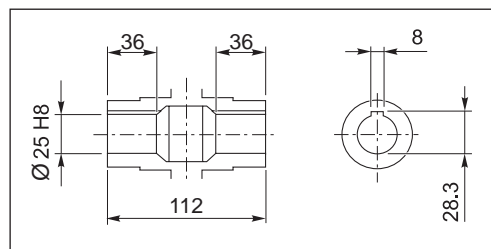

Albero lento cavo / Hollow output shaft

		Dimensioni / Dimensions												
AS	A	B	C	M	K	Rapporti / Ratio								
						5...30			40...60			80...100		
						D	E	F	D	E	F	D	E	F
AS302	73	69.6	86	M5	98	24	8	27.3	19	6	21.8	14	5	16.3
...

CM070 - U - AS...

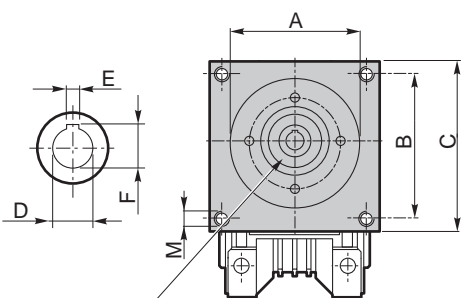

Connessione con boccola o giunto in funzione del diametro dell'albero motore.

Connection with sleeve or coupling depending on motorshaft's diameter.

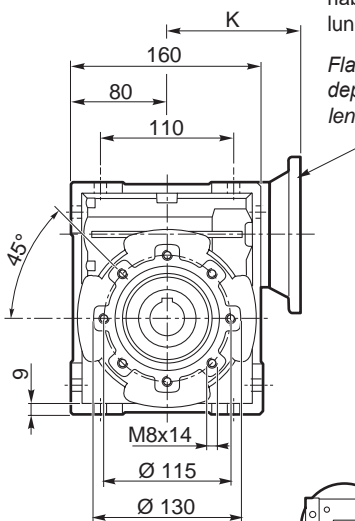

Lo spessore della flangia è variabile in funzione delle diverse lunghezze dell'albero motore.

Flange's thickness may vary depending on motorshaft's length.

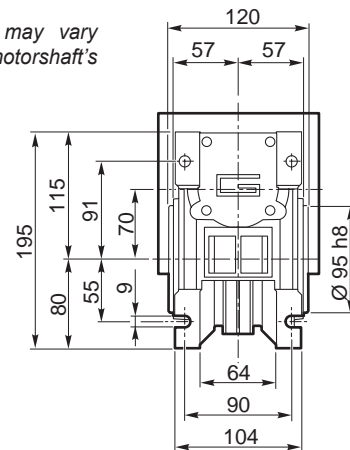

BE28

III 11

Kg
7.5

CM070.. F

CL070

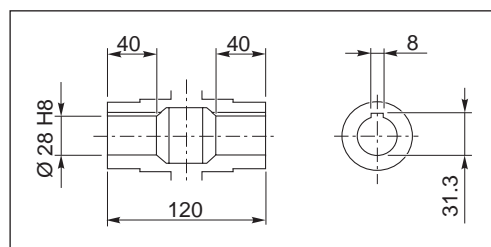

Albero lento cavo / Hollow output shaft

		Dimensioni / Dimensions												
AS	A	B	C	M	K	Rapporti / Ratio								
						5...20			25...40			50...100		
						D	E	F	D	E	F	D	E	F
...	28	8	31.3	24	8	27.3	19	6	21.8

IP 55
CM

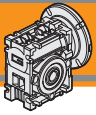

CM

Riduttori a vite senza fine
Wormgearboxes

Dimensioni flange uscita

Output flange dimensions

CM.../... F... Flange uscita / Output flanges

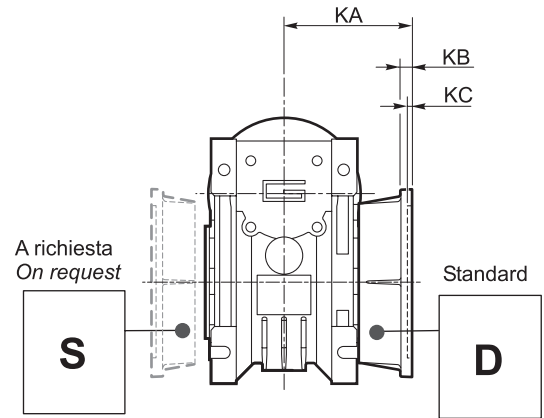
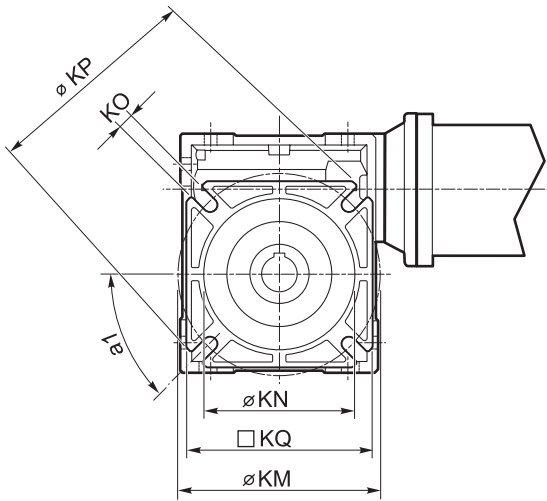

	CM..F									CM..F28							CM..F30								
	a1	KA	KB	KC	KM	KN _{H8}	KO	KP	KQ	KA	KB	KC	KM	KN _{H8}	KO	KP	KQ	KA	KB	KC	KM	KN _{H8}	KO	KP	KQ
026	45°	45	6	4.5	55-69	40	6.5(n.4)	75	70	44	6.5	5	56-64	40	6.5	70	60	48	6.5	5	68	50	6.5	80	70

CM	CM..F									CM..FB							CM..FL								
	a1	KA	KB	KC	KM	KN _{H8}	KO	KP	KQ	KA	KB	KC	KM	KN _{H8}	KO	KP	KQ	KA	KB	KC	KM	KN _{H8}	KO	KP	KQ
030	45°	54.5	6	4	68	50	6.5(n.4)	80	70	—	—	—	—	—	—	—	—	—	—	—	—	—	—	—	—
040	45°	67	7.5	4	80-95	60	9(n.4)	110	95	80	8.5	5	115-125	95	9.5(n.4)	140	112	97	7.5	4.5	80-95	60	9(n.4)	110	95
050	45°	90	9	5	90-110	70	11(n.4)	125	110	89	9	5	130-145	110	9.5(n.4)	160	132	120	9	5	90-110	70	11(n.4)	125	110
063	45°	82	10	6	150-160	115	11(n.4)	180	142	98	10	5	165-180	130	11(n.4)	200	160	112	10	6	150-160	115	11(n.4)	180	142
070	45°	107	13	6	165-180	130	14(n.4)	200	170	—	—	—	—	—	—	—	—	—	—	—	—	—	—	—	—

Opzioni

Options

VS - Vite sporgente / Extended input shaft

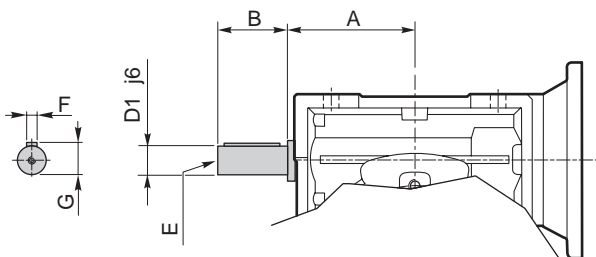

CM	A	B	D ₁ j6	E	F	G
030	45	20	9	M4	3	10.2
040	53	23	11	M5	4	12.5
050	64	30	14	M6	5	16
063	75	40	19	M6	6	21.5
070	84	40	19	M6	6	21.5

Costruito su richiesta
Built on request

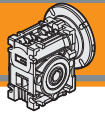

SC - Safety cover

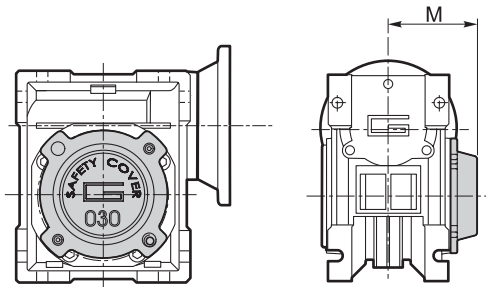

CM	M
030	47
040	54.5
050	62.5
063	73
070	75

WD - Washdown cover

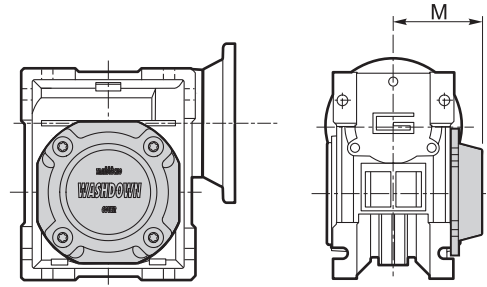

CM	M
026 (*)	37.5
030	48
040	55.5
050	63.5
063	71.5
070	76

(*)

Nota: Viti escluse dalla fornitura

Note: Screws not included in the supply

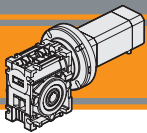

Motoriduttori brushless CC a vite senza fine Brushless DC Wormgearmotors

Accessori

Accessories

Albero lento

Output shaft

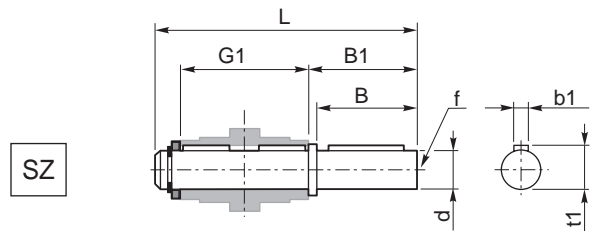
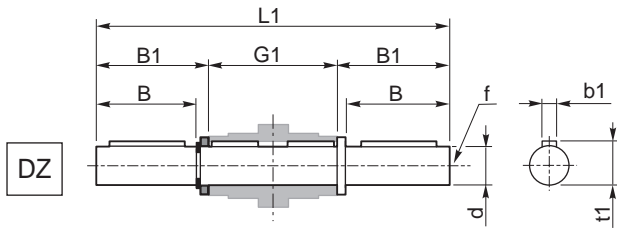

	d h7	B	B1	G1	L	L1	f	b1	t1
CM 030	14	30	32.5	63	102	128	M6	5	16
CM 040	18	40	43	78	128	164	M6	6	20.5
CM 050	25	50	53.5	92	153	199	M10	8	28
CM 063	25	50	53.5	112	173	219	M10	8	28
CM 070	28	60	63.5	120	192	247	M10	8	31

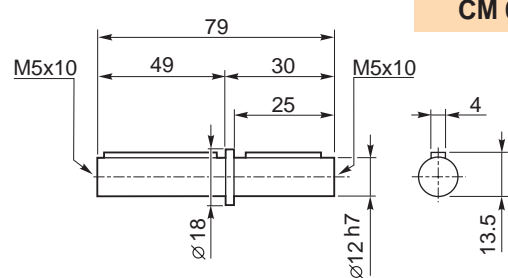

CM 026

Braccio di reazione

Torque arm

	K1	G	KG	KH	R
CM 030	85	14	23	8	15
CM 040	100	14	31	10	18
CM 050	100	14	38	10	18
CM 063	150	14	47.5	10	18
CM 070	200	25	46.5	20	30

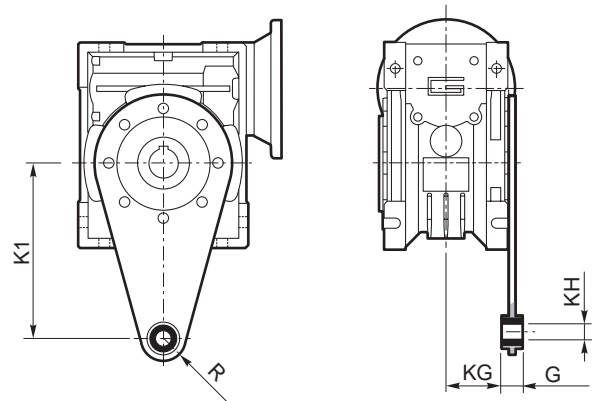

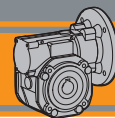

Dimensioni

Dimensions

CL 070 U

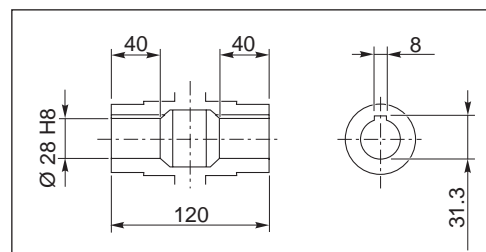
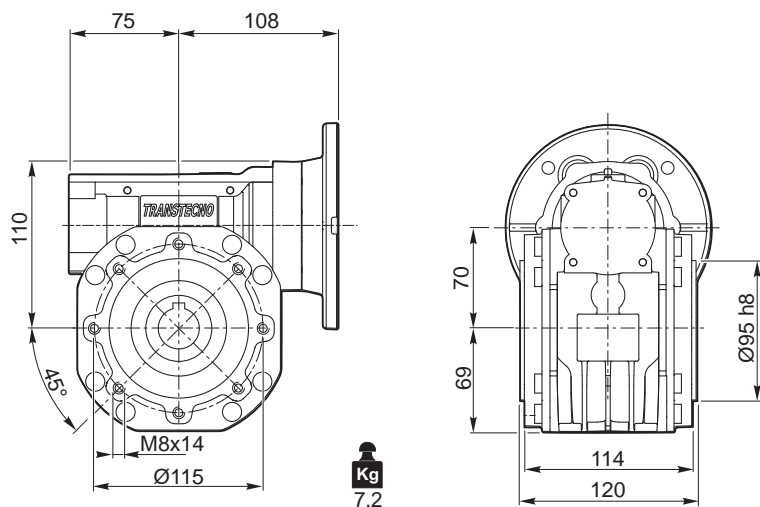

Albero lento cavo / Hollow output shaft

CL 070 F

CLP./070 F

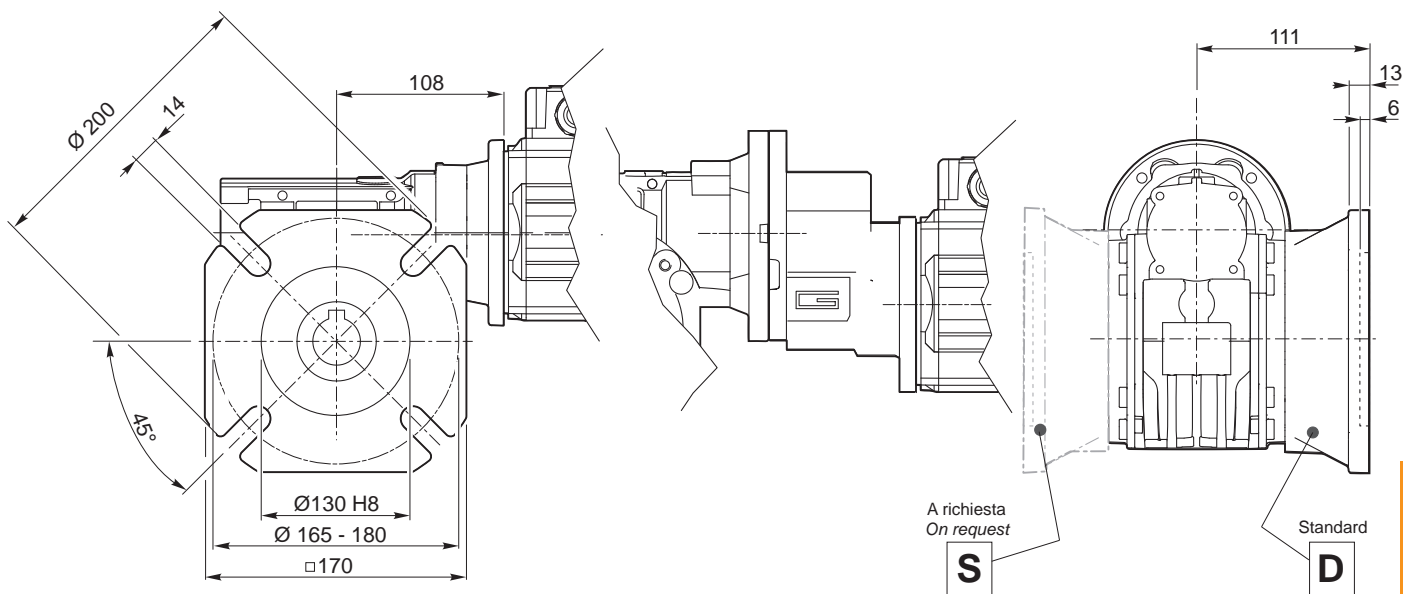

CL

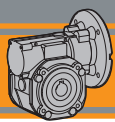

Accessori

Accessories

Albero lento semplice e doppio

Single and double output shaft

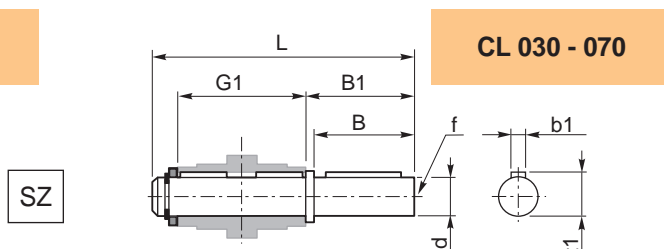
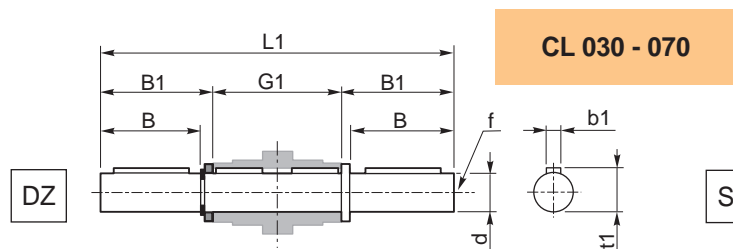

CL	d _{h7}	B	B1	G1	L	L1	f	b1	t1
030	14	30	32.5	63	102	128	M6	5	16
040	18	40	43	78	128	164	M6	6	20.5
050	25	50	53.5	92	153	199	M10	8	28
063	25	50	53.5	112	173	219	M10	8	28
070	28	60	63.5	120	192	247	M10	8	31

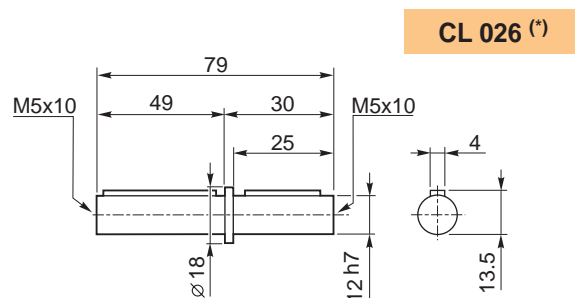

(*)
Nota: disponibile solo per cavo uscita Ø12
Note: available for output hollow shaft Ø12 only

Braccio di reazione

Torque arm

CL	K1	G	KG	KH	R
030	85	14	23	8	15
040	100	14	31	10	18
050	100	14	38	10	18
063	150	14	47.5	10	18
070	200	25	46.5	20	30

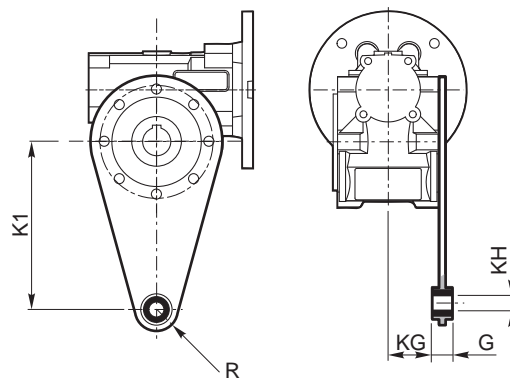

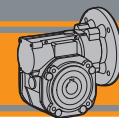

Accessori

Accessories

SC - Safety Cover

CL	M
030	47
040	54.5
050	62.5
063	73
070	75

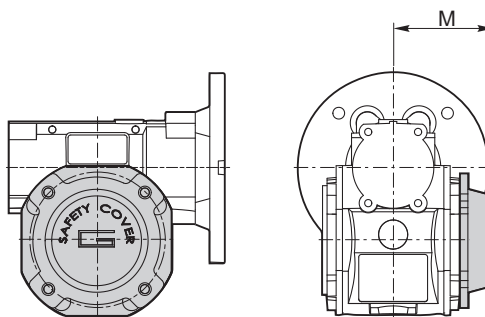

WD - Kit washdown cover

CL	M
026*	37.5
030	48
040	55.5
050	63.5
063	71.5
070	76

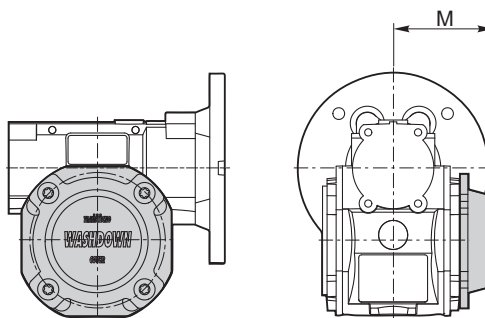

(*)
Nota: Viti escluse dalla fornitura
Note: Screws not provided

Opzioni

Options

VS - Vite sporgente / Extended input shaft

CL	A	B	D ₁ j6	E	F	G
030	45	20	9	M4	3	10.2
040	53	23	11	M5	4	12.5
050	64	30	14	M6	5	16
063	75	40	19	M6	6	21.5
070	84	40	19	M6	6	21.5

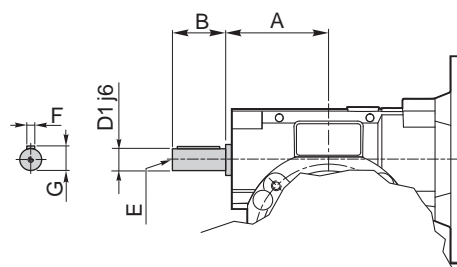

Costruito su richiesta
Built on request

Wir kombinieren Elektronik und Mechanik für Sie. Und das seit über 70 Jahren.

Die Ott GmbH & Co. KG bietet als Produktions-, Handels- und Dienstleistungsunternehmen Komponenten und Systeme aus dem Bereich der Antriebstechnik und Elektronik an. Wir sehen uns als Produzent, Modifikator und Händler von Antrieben und Steuerungen und sind als verlässlicher Business-Partner bekannt. Aufgrund der hohen Qualität und Langlebigkeit unserer Produkte, genießen wir einen hervorragenden Ruf in der Industrie.

Als Vertretung unter anderem der Firmen Nidec, DKM, Transtecno, Ewellix und Kaleja führen wir ein Lager, in dem ständig circa 100.000 Motoren und Steuerungen vorrätig gehalten werden. Dies ermöglicht es, schnell auf Ihre Anforderungen zu reagieren. Darüber hinaus werden in unserer eigenen Fertigung kundenspezifische Änderungen an Motoren, wie Wellenbearbeitungen, Aufbau von Inkrementalgebern, Bremsen, Sonder-getriebe und Steckverbindungen, realisiert.

Diese Sonderfertigungen führen wir auch bei kleinsten Stückzahlen durch.

Damit können komplette Systemlösungen nach Ihren Aufgabenstellungen projiziert und gefertigt werden. Um die optimale Lösung für jedes Projekt zu erarbeiten, stehen unsere erfahrenen und langjährigen Vertriebsingenieure mit kompetentem Fachwissen jederzeit zur Verfügung.

Unser Vorgehen: Wir informieren uns über Ihre Anforderungen, wählen mit Ihrer Entwicklungsabteilung die passenden Antriebe und Steuerungen aus und erarbeiten wirtschaftliche Systemlösungen.

Gemäß dem Slogan „Standardisierte Individualität“ wird wo möglich eine Standard- und wo nötig eine individuelle Lösung erarbeitet.



Kataloge entdecken



Ott GmbH & Co. KG
Baarstraße 3 • D-78652 Deißlingen
Telefon: +49 7420 / 9399-0

info@ott-antriebe.de
www.ott-antriebe.de