

## DC-, BLDC- UND AC-MOTOREN BIS SCHUTZKLASSE IP66



**MIT SCHNECKEN-, STIRNRAD ODER  
PLANETENGETRIEBE**



**Auf allen folgenden Seiten gilt:  
Änderungen und Irrtümer  
auch technischer Art vorbehalten!**



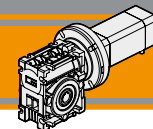

<b>Indice</b>	<b>Index</b>	<b>Pag. Page</b>
Caratteristiche tecniche	<i>Technical features</i>	<b>B2</b>
Designazione	<i>Classification</i>	<b>B2</b>
Simbologia	<i>Symbols</i>	<b>B3</b>
Lubrificazione e temperatura	<i>Lubrication and temperature</i>	<b>B3</b>
Carichi radiali	<i>Radial loads</i>	<b>B3</b>
Dati di dentatura	<i>Toothing data</i>	<b>B4</b>
Rendimento	<i>Efficiency</i>	<b>B4</b>
CM026 con motore brushless BLS 022.240	<i>CM026 with brushless motor BLS 022.240</i>	<b>B5</b>
CM030 con motore brushless BLS 043.240	<i>CM030 with brushless motor BLS 043.240</i>	<b>B6</b>
CM030 con motore brushless BL 070.240	<i>CM030 with brushless motor BLS 070.240</i>	<b>B7</b>
CM030 con motore brushless BL 070.480	<i>CM030 with brushless motor BL 070.480</i>	<b>B7</b>
CM040 con motore brushless BLS 043.240	<i>CM040 with brushless motor BLS 043.240</i>	<b>B8</b>
CM040 con motore brushless BL 070.240	<i>CM040 with brushless motor BL 070.240</i>	<b>B9</b>
CM040 con motore brushless BL 070.480	<i>CM040 with brushless motor BL 070.480</i>	<b>B9</b>
CM040 con motore brushless BL 140.480	<i>CM040 with brushless motor BL 140.480</i>	<b>B9</b>
CM040 con motore brushless BL 210.480	<i>CM040 with brushless motor BL 210.480</i>	<b>B9</b>
CM050 con motore brushless BL 070.240	<i>CM050 with brushless motor BL 070.240</i>	<b>B10</b>
CM050 con motore brushless BL 070.480	<i>CM050 with brushless motor BL 070.480</i>	<b>B10</b>
CM050 con motore brushless BL 140.480	<i>CM050 with brushless motor BL 140.480</i>	<b>B10</b>
CM050 con motore brushless BL 210.480	<i>CM050 with brushless motor BL 210.480</i>	<b>B10</b>
CM063 con motore brushless BL 070.240	<i>CM063 with brushless motor BL 070.240</i>	<b>B11</b>
CM063 con motore brushless BL 070.480	<i>CM063 with brushless motor BL 070.480</i>	<b>B11</b>
CM063 con motore brushless BL 140.480	<i>CM063 with brushless motor BL 140.480</i>	<b>B11</b>
CM063 con motore brushless BL 210.480	<i>CM063 with brushless motor BL 210.480</i>	<b>B11</b>
Dati tecnici	<i>Technical data</i>	<b>B12</b>
Dimensioni CM con flange motore AS	<i>CM dimensions with motor flanges AS</i>	<b>B13</b>
Flange uscita	<i>Output flange</i>	<b>B16</b>
Opzioni	<i>Options</i>	<b>B16</b>
Accessori	<i>Accessories</i>	<b>B17</b>

Questa sezione annulla e sostituisce ogni precedente edizione o revisione. Qualora questa sezione non Vi sia giunta in distribuzione controllata, l'aggiornamento dei dati ivi contenuto non è assicurato. **In tal caso la versione più aggiornata è disponibile sul nostro sito internet [www.intecno-srl.com](http://www.intecno-srl.com)**

*This section replaces any previous edition and revision. If you obtained this catalogue other than through controlled distribution channels, the most up to date content is not guaranteed. In this case the latest version is available on our web site [www.intecno-srl.com](http://www.intecno-srl.com)*

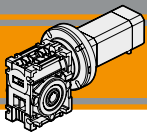

# Motoriduttori brushless CC a vite senza fine Brushless DC Wormgearmotors

## Caratteristiche tecniche

## Technical features

Le caratteristiche principali dei motoriduttori brushless CC a vite senza fine della serie CM sono:

- Alimentazione in bassa tensione 24/36/48 Vcc
- Motore protezione IP55
- Coppie motore disponibili da 0.22 a 2.1 Nm
- Carcasse dei riduttori in pressofusione di alluminio
- Lubrificazione permanente con olio sintetico
- Disponibili anche nella versione con solo riduttore, sia con flangia di entrata standard che con flangia e manicotto dedicati

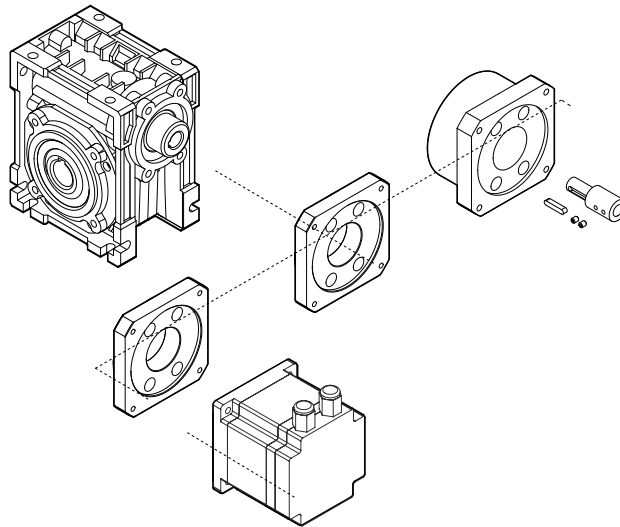

The main features of CM brushless DC wormgearmotors range are:

- Low voltage power supply 24/36/48 Vdc
- Motor protection IP55
- Motor torque ratings available from 0.22 up to 2.1 Nm
- Die-cast aluminium housings
- Permanent synthetic oil long life lubrication
- Gearbox only version also available, with either standard input flange or customized flange and coupling

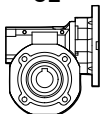

## Designazione

## Classification

RIDUTTORE / GEARBOX				MOTORE / MOTOR		
CM	030	20	U	BL070.480	48V	BR
Tipo Type	Grandezza Size	Rapporto in Ratio in	Versione Version	Tipo Type	Tensione Voltage	Freno Brake
<b>CM</b>  <b>CL</b>  a richiesta on request	<b>026</b> <b>030</b> <b>040</b> <b>050</b> <b>063</b>	Vedere tabelle See tables	<b>U</b> <b>FD</b> <b>FS</b> <b>FLD</b> <b>FLS</b> <b>FBD</b> <b>FBS</b>	<b>BLS022.240</b> <b>BLS043.240</b> <b>BL070.240</b> <b>BL070.48B</b> <b>BL070.480</b> <b>BL140.480</b> <b>BL210.480</b> <b>BL210.48E</b>	<b>24V-36V</b> <b>24V-36V</b> <b>24V</b> <b>48V</b> <b>48V</b> <b>48V</b> <b>48V</b> <b>48V</b>	<b>24V</b> <b>48V</b>  

Versione Riduttore  
Gearbox Version

Albero di uscita  
Output shaft

Braccio di reazione  
Torque arm

Angolo  
Angle

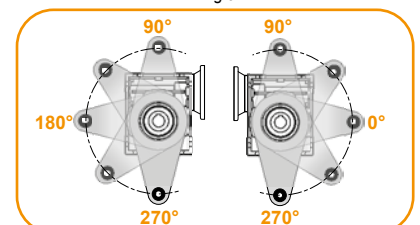
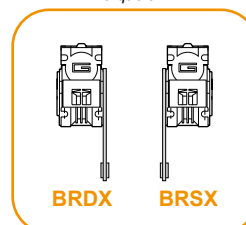
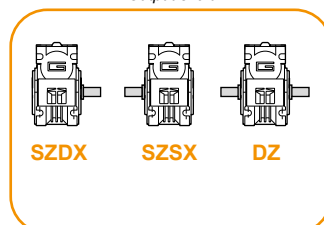
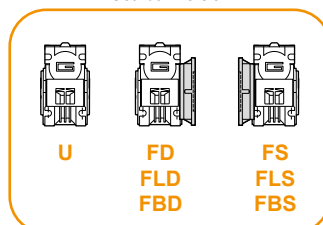

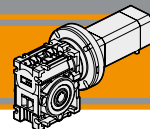

### Simbologia

### Symbols

Ns	n° stadi / No. stages	n <sub>1MAX</sub>	[Rpm]	Velocità max entrata / Max input speed
ir	rappporto reale / real ratio	V	[V]	Tensione / Voltage
M <sub>2</sub>	[Nm] coppia in uscita output torque	n <sub>2</sub>	[Rpm]	Velocità in uscita / Output Speed
A <sub>2</sub>	[N] Carico assiale ammissibile in uscita Permitted output axial load	IP		Grado di protezione / Enclosure protection
R <sub>2</sub>	[N] Carico radiale ammissibile in uscita Permitted output radial load	Kg		Peso / Weight
Pn <sub>1</sub>	[kW] Potenza nominale in entrata Nominal input power	sf		Fattore di servizio / Service Factor
Mn <sub>2</sub>	[Nm] Coppia nominale in uscita in funzione di Pn1 Nominal output torque referred to Pn1	Rd	%	Rendimento dinamico / Dynamic efficiency
		Rs	%	Rendimento statico / Static efficiency
		Z		Numero di principi della vite / Worm starts
		β		Angolo d'elica / Helix angle

### Lubrificazione e temperatura

### Lubrication and temperature

Tutti i motoriduttori CM sono forniti completi di lubrificante sintetico viscosità 320, pertanto possono essere installati in qualunque posizione di montaggio e non necessitano di manutenzione.

*Permanent synthetic oil long-life lubrication (viscosity grade 320) makes it possible to use the CM worm gearmotors in all mounting positions; for this reason they can be installed in any assembly position and do not require maintenance.*

Temperatura ambiente 0 ÷ 40 °C (in assenza di congelamento ed in assenza di condensa).

*Ambient temperature 0 ÷ 40 °C (in the absence of freezing and condensation).*

Per temperature diverse, contattare nostro UT.

*For temperature outside this range please contact our technical dept.*

### Carichi radiali

### Radial loads

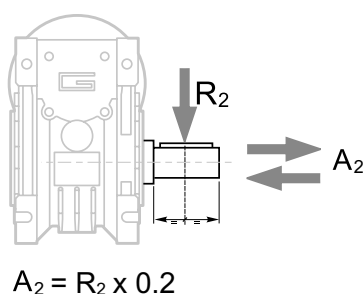

n <sub>2</sub> [min <sup>-1</sup> ]	R <sub>2</sub> [N]				
	CM026	CM030	CM040	CM050	CM063
187	400	674	1264	1770	2445
140	490	743	1392	1949	2692
93	480	851	1596	2234	3085
70	610	936	1754	2456	3392
56	610	1008	1890	2646	3654
47	610	1069	2004	2805	3874
35	610	1179	2210	3095	4273
28	610	1270	2381	3334	4603
23	610	1356	2542	3559	4915
18	610	1471	2759	3862	5334
14	610	1600	3000	4200	5800

Quando il carico radiale risultante non è applicato sulla mezza-ria dell'albero occorre calcolare quello effettivo con la seguente formula:

*When the resulting radial load is not applied on the centre line of the shaft it is necessary to calculate the effective load with the following formula:*

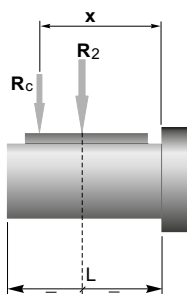

	CM				
	026	030	040	050	063
a	56	65	84	101	120
b	43	50	64	76	95
R <sub>2MAX</sub>	610	1600	3000	4200	5800

$$R_c = \frac{R_2 \cdot a}{(b+x)} \leq R_{2MAX}$$

$$R \leq R_c$$

a. b = valori riportati nella tabella  
a. b = values given in the table

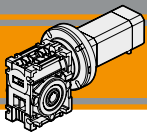

### Dati di dentatura

### Toothing data

	Dati della coppia vite-corona Worm wheel data	Rapporto / Ratio											
		5	7.5	10	15	20	25	30	40	50	60	80	100
CM026	Z	6	4	3	2	2		1	1	1	1		
	$\beta$	34° 35'	24° 41'	19° 1'	12° 57'	10° 30'		6° 33'	5° 17'	4° 26'	3° 49'		
CM030	Z	6	4	3	2	2	2	1	1	1	1	1	1
	$\beta$	27° 4'	24° 28'	18° 50'	12° 49'	10° 23'	8° 43'	6° 29'	5° 14'	4° 23'	3° 46'	2° 57'	2° 25'
CM040	Z	6	4	3	2	2	2	1	1	1	1	1	1
	$\beta$	34° 19'	24° 28'	18° 50'	12° 49'	10° 23'	8° 43'	6° 29'	5° 14'	4° 23'	3° 46'	2° 57'	2° 25'
CM050	Z	6	4	3	2	2	2	1	1	1	1	1	1
	$\beta$	33° 37'	23° 54'	18° 23'	12° 29'	10° 6'	8° 28'	6° 19'	5° 5'	4° 15'	3° 39'	2° 51'	2° 20'
CM063	Z	6	4	3	2	2	2	1	1	1	1	1	1
	$\beta$	34° 23'	24° 31'	18° 53'	12° 50'	10° 24'	8° 44'	6° 30'	5° 14'	4° 23'	3° 47'	2° 57'	2° 25'

### Rendimento

### Efficiency

	$n_1$ [min <sup>-1</sup> ]	Rendimento Efficiency	Rapporto / Ratio											
			5	7.5	10	15	20	25	30	40	50	60	80	100
CM026	2800	Rd	89	87	85	83	80		73	68	64	60		
		Rs	72	71	68	61	56	46	41	36	34			
CM030	2800	Rd	89	88	86	84	81	78	74	70	65	62	57	52
		Rs	72	67	63	55	50	43	39	35	31	27	23	21
CM040	2800	Rd	90	89	87	84	83	80	77	73	69	66	60	56
		Rs	74	71	67	60	55	51	45	40	36	32	28	24
CM050	2800	Rd	91	90	88	86	84	82	78	74	71	68	62	58
		Rs	73	70	66	59	55	51	44	39	35	32	27	23
CM063	2800	Rd	91	90	88	86	84	83	79	76	73	70	65	60
		Rs	73	71	67	60	55	51	45	40	36	33	28	24

### Reversibilità e irreversibilità

### Reversibility and irreversibility

La tabella sottostante riporta a titolo puramente indicativo i vari gradi di reversibilità/irreversibilità nei riduttori a vite senza fine in funzione del rendimento dinamico Rd e statico Rs.

The table below is provided for reference purposes only. It contains the various degrees of reversibility/irreversibility of wormgearboxes in relation to dynamic Rd and static Rs efficiency.

Rd	Reversibilità e irreversibilità dinamica	Dynamic reversibility and irreversibility
> 0.60	Reversibilità dinamica	Dynamic reversibility
0.50 - 0.60	Reversibilità dinamica incerta	Uncertain dynamic reversibility
0.40 - 0.50	Buona irreversibilità dinamica	Good dynamic irreversibility
<0.40	Irreversibilità dinamica	Dynamic irreversibility
Rs	Reversibilità e irreversibilità statica	Static reversibility and irreversibility
> 0.55	Reversibilità statica	Static reversibility
0.50 - 0.55	Reversibilità statica incerta	Uncertain static reversibility
<0.50	Irreversibilità statica	Static irreversibility



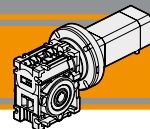

CM026 con motore brushless CC

CM026 with brushless DC motor

CM026	BLS022.240													
	24V						36V							
	n <sub>2</sub> MIN		sf		n <sub>2</sub> MAX		n <sub>1</sub> MAX [ rpm ]	n <sub>2</sub> MIN		n <sub>2</sub> MAX		n <sub>1</sub> MAX [ rpm ]		
M <sub>2</sub>		M <sub>2</sub>		M <sub>2</sub>		M <sub>2</sub>			M <sub>2</sub>					
ir	60	0.9	27	600	1.0	10	3000	80	0.9	21	800	1.0	8.0	4000
5	40	1.3	19	400	1.5	7.9		53	1.3	16	533	1.5	6.0	
7.5	30	1.7	16	300	1.9	5.8		40	1.7	12	400	1.9	4.7	
10	20	2.2	12	200	2.7	4.1		27	2.3	9.1	267	2.8	3.2	
15	15	2.8	9.3	150	3.5	3.1		20	2.9	6.9	200	3.6	2.5	
20	10	3.6	7.5	100	4.8	2.5		13	3.8	5.8	133	5.0	2.0	
30	7.5	4.4	4.8	75	6.0	1.8		10	4.6	4.1	100	6.2	1.5	
40	6	4.8	4.2	60	7.0	1.4		8.0	5.2	3.5	80	7.3	1.1	
50	5	5.4	3.3	50	7.8	1.1		6.7	5.8	2.9	67	8.2	0.9	
60														

Attenzione: superamento della coppia nominale supportata dal riduttore per servizio S1. Contattare il ns. servizio tecnico  
Attention: rated torque withstood by gear reducer for service in S1 is exceeded. Please, contact our technical office.

Tipo Type	Numero di poli Number of poles	Numero di fasi Number of phase	Tensione Rated voltage [ V ]	Numero di giri Rated speed [ rpm ]	Coppia nominale Rated torque [ Nm ]	Potenza nominale Rated power [ W ]
BLS022.240	4	3	36	4000	0.22	92
			24	3000		70
Tipo Type	Coppia massima Peak torque [ Nm ]	Corrente nominale Rated current [ A ]	Resistenza Resistance [ ohm ]	Induttanza Inductance [ mH ]	Corrente massima Peak current [ A ]	Peso Weight [ kg ]
BLS022.240	0.44	3.7	0.64	3.1	7.4	0.72

Azionamenti  
Drives



CM026..U  
+  
BLS022.240

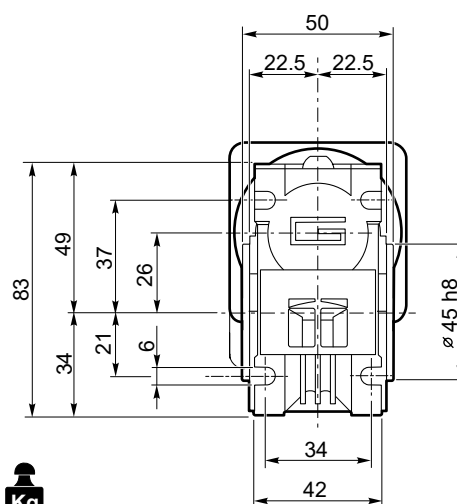
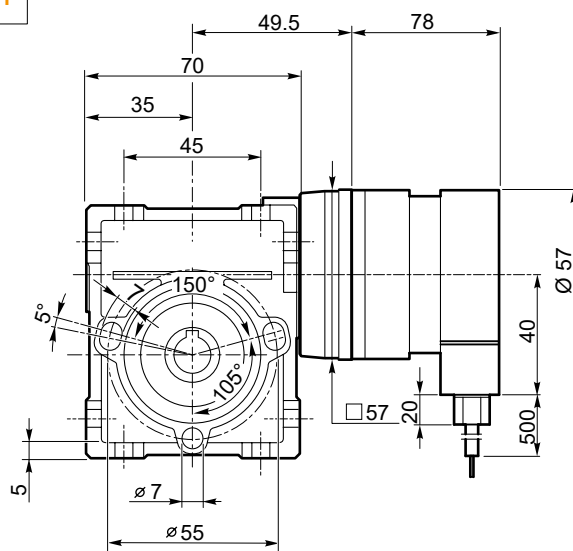

**Kg**  
2.5

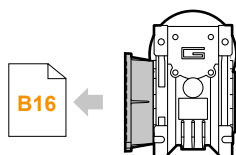

CM026.. F

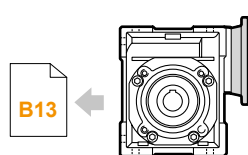

CM026.. AS...

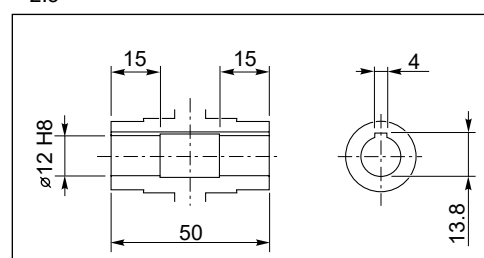

Albero lento cavo / Hollow output shaft

Brushless DC

CM

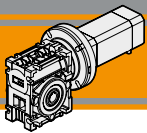

# Motoriduttori brushless CC a vite senza fine Brushless DC Wormgearmotors

CM030 con motore brushless CC

CM030 with brushless DC motor

CM030	BLS043.240													
	24V						36V							
	n <sub>2</sub> MIN		sf		n <sub>2</sub> MAX		n <sub>1</sub> MAX [rpm]	n <sub>2</sub> MIN		n <sub>2</sub> MAX		n <sub>1</sub> MAX [rpm]		
M <sub>2</sub>		M <sub>2</sub>		M <sub>2</sub>		M <sub>2</sub>			M <sub>2</sub>					
5	60	1.7	20	600	1.9	6.8	3000	80	1.7	20	800	1.9	6.8	4000
7.5	40	2.5	14	400	2.8	5.3		53	2.5	14	533	2.8	5.3	
10	30	3.2	12	300	3.7	4.3		40	3.2	12	400	3.7	4.3	
15	20	4.4	8.6	200	5.4	3.0		26	4.4	8.6	267	5.4	3.0	
20	15	5.5	5.8	150	7.0	2.0		20	5.5	5.8	200	7.0	2.0	
25	12	6.5	4.8	120	8.4	1.8		16	6.5	4.8	160	8.4	1.8	
30	10	7.1	5.5	100	9.5	1.9		13	7.1	5.5	133	9.5	1.9	
40	7.5	8.4	3.9	75	12	1.3		10	8.4	3.9	100	12	1.3	
50	6.0	9.7	3.0	60	14	1.1		8	9.7	3.0	80	14	1.1	
60	5.0	11	2.5	50	16	0.9		6.6	11	2.5	67	16	0.9	
80	3.7	12	1.8	38	17	0.7	5	12	1.8	50	17	0.7		
100	3.0	14	1.4	30	16	0.7	4	14	1.4	40	16	0.7		

Attenzione: superamento della coppia nominale supportata dal riduttore per servizio S1. Contattare il ns. servizio tecnico  
Attention: rated torque withstood by gear reducer for service in S1 is exceeded. Please, contact our technical office.

Tipo Type	Numero di poli Number of poles	Numero di fasi Number of phase	Tensione Rated voltage [V]	Numero di giri Rated speed [rpm]	Coppia nominale Rated torque [Nm]	Potenza nominale Rated power [W]
BLS043.240	4	3	36	4000	0.43	180
	4	3	24	3000	0.43	130
Tipo Type	Coppia massima Peak torque [Nm]	Corrente nominale Rated current [A]	Resistenza Resistance [ohm]	Induttanza Inductance [mH]	Corrente massima Peak current [A]	Peso Weight [kg]
BLS043.240	0.86	6	0.35	1.0	12.0	1.25

Azionamenti Drives

H1

CM030..U  
+  
BLS043.240

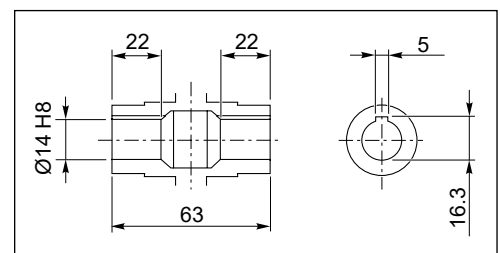
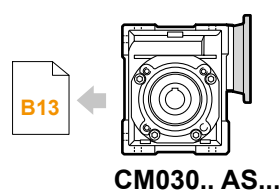
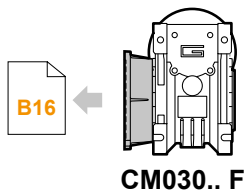
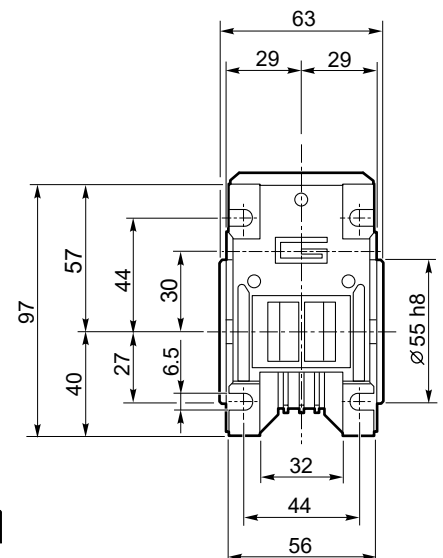
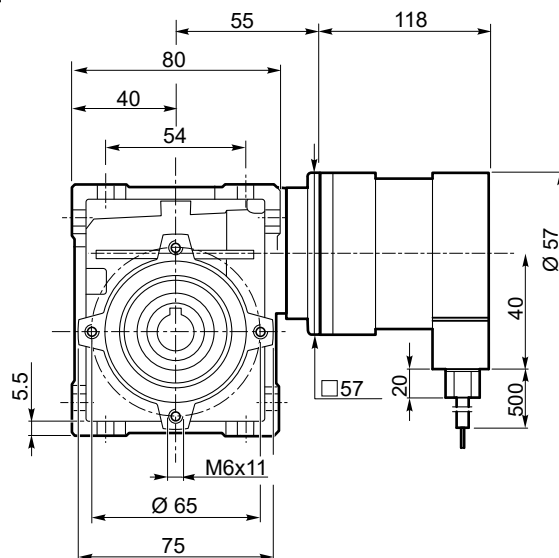

Albero lento cavo / Hollow output shaft



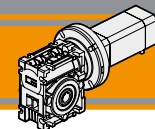

CM030 con motore brushless CC

CM030 with brushless DC motor

CM030	BL070.240 / BL070.480 / BL070.48B						
	24V / 48V						
ir	n <sub>2</sub> MIN			n <sub>2</sub> MAX			n <sub>1</sub> MAX [ rpm ]
		M <sub>2</sub>	sf		M <sub>2</sub>	sf	
5	60	2.8	11	600	3.1	4.2	3000
7.5	40	4.1	8.0	400	4.6	3.2	
10	30	5.3	6.4	300	6.0	2.7	
15	20	7.2	4.9	200	8.8	1.8	
20	15	9.1	3.2	150	11	1.2	
25	12	11	2.5	120	14	1.1	
30	10	12	2.9	100	16	1.2	
40	7.5	14	2.1	75	20	0.8	
50	6.0	16	1.6	60	23	0.7	

Attenzione: superamento della coppia nominale supportata dal riduttore per servizio S1. Contattare il ns. servizio tecnico  
Attention: rated torque withstood by gear reducer for service in S1 is exceeded. Please, contact our technical office.

Tipo Type	Numero di poli Number of poles	Numero di fasi Number of phase	Tensione Rated voltage [ V ]	Numero di giri Rated speed [ rpm ]	Coppia nominale Rated torque [ Nm ]	Potenza nominale Rated power [ W ]
BL070.240	8	3	24	3000	0.7	220
BL070.480 BL070.48B	8	3	48	3000	0.7	220

  

Tipo Type	Coppia massima Peak torque [ Nm ]	Corrente nominale Rated current [ A ]	Resistenza Resistance [ ohm ]	Induttanza Inductance [ mH ]	Corrente massima Peak current [ A ]	Peso Weight [ kg ]
BL070.240	2.1	13	0.091	0.23	26	2.1
BL070.480 BL070.48B	1.4	6.5	0.34	1.0	13	2.1

Azionamenti  
Drives



CM030..U  
+  
BL070.240  
BL070.480

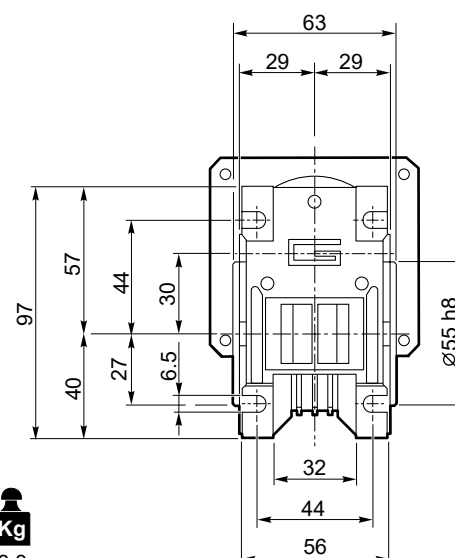
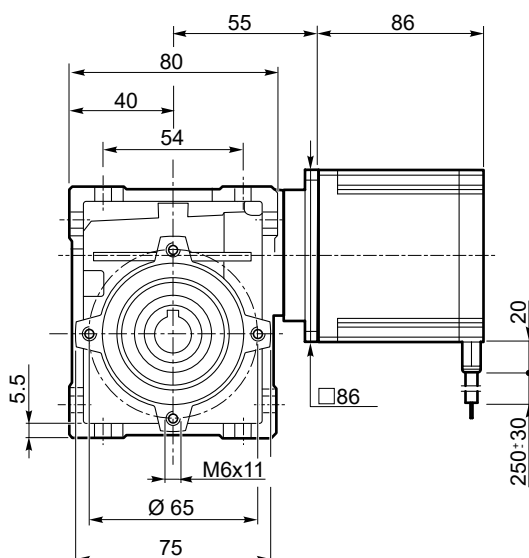

**Kg**  
3.3

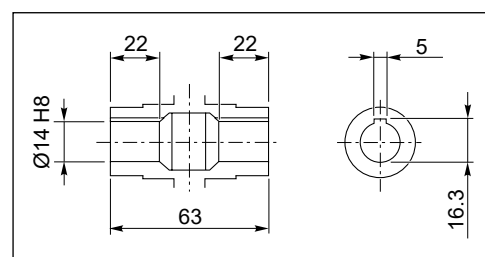
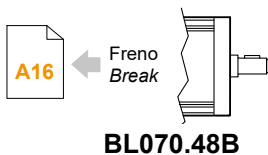
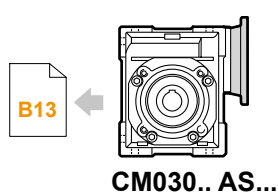
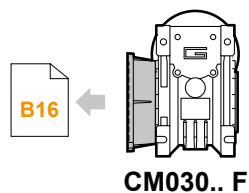

Albero lento cavo / Hollow output shaft

Brushless DC

CM

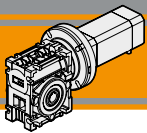

# Motoriduttori brushless CC a vite senza fine Brushless DC Wormgearmotors

CM040 con motore brushless CC

CM040 with brushless DC motor

CM040	BLS043.240											
	24V						36V					
	n <sub>2</sub> MIN		sf	n <sub>2</sub> MAX		n <sub>1</sub> MAX [rpm]	n <sub>2</sub> MIN		sf	n <sub>2</sub> MAX		n <sub>1</sub> MAX [rpm]
M <sub>2</sub>		M <sub>2</sub>			M <sub>2</sub>			M <sub>2</sub>				
5	60	1.8	35	600	2.0	14	80	1.8	35	800	2.0	14
7.5	40	2.6	26	400	2.9	11	53	2.6	26	533	2.9	11
10	30	3.4	20	300	3.7	8.9	40	3.4	20	400	3.7	8.9
15	20	4.6	15	200	5.4	6.5	26	4.6	15	267	5.4	6.5
20	15	5.8	10	150	7.2	4.3	20	5.8	10	200	7.2	4.3
25	12	6.9	7.8	120	8.6	3.2	16	6.9	7.8	160	8.6	3.2
30	10	7.9	9.4	100	10	3.8	13	7.9	9.4	133	10	3.8
40	7.5	9.6	6.8	75	13	2.6	10	9.6	6.8	100	13	2.6
50	6.0	12	5.5	60	15	2.1	8	12	5.5	80	15	2.1
60	5.0	12	4.7	50	17	1.7	6.6	12	4.7	67	17	1.7
80	3.7	14	3.6	38	21	1.3	5	14	3.6	50	21	1.3
100	3.0	16	2.8	30	24	1.0	4	16	2.8	40	24	1.0

Tipo Type	Numero di poli Number of poles	Numero di fasi Number of phase	Tensione Rated voltage [V]	Numero di giri Rated speed [rpm]	Coppia nominale Rated torque [Nm]	Potenza nominale Rated power [W]
BLS043.240	4	3	36	4000	0.43	180
	4	3	24	3000	0.43	130
Tipo Type	Coppia massima Peak torque [Nm]	Corrente nominale Rated current [A]	Resistenza Resistance [ohm]	Induttanza Inductance [mH]	Corrente massima Peak current [A]	Peso Weight [kg]
BLS043.240	0.86	6	0.35	1.0	12.0	1.25

Azionamenti Drives → H1

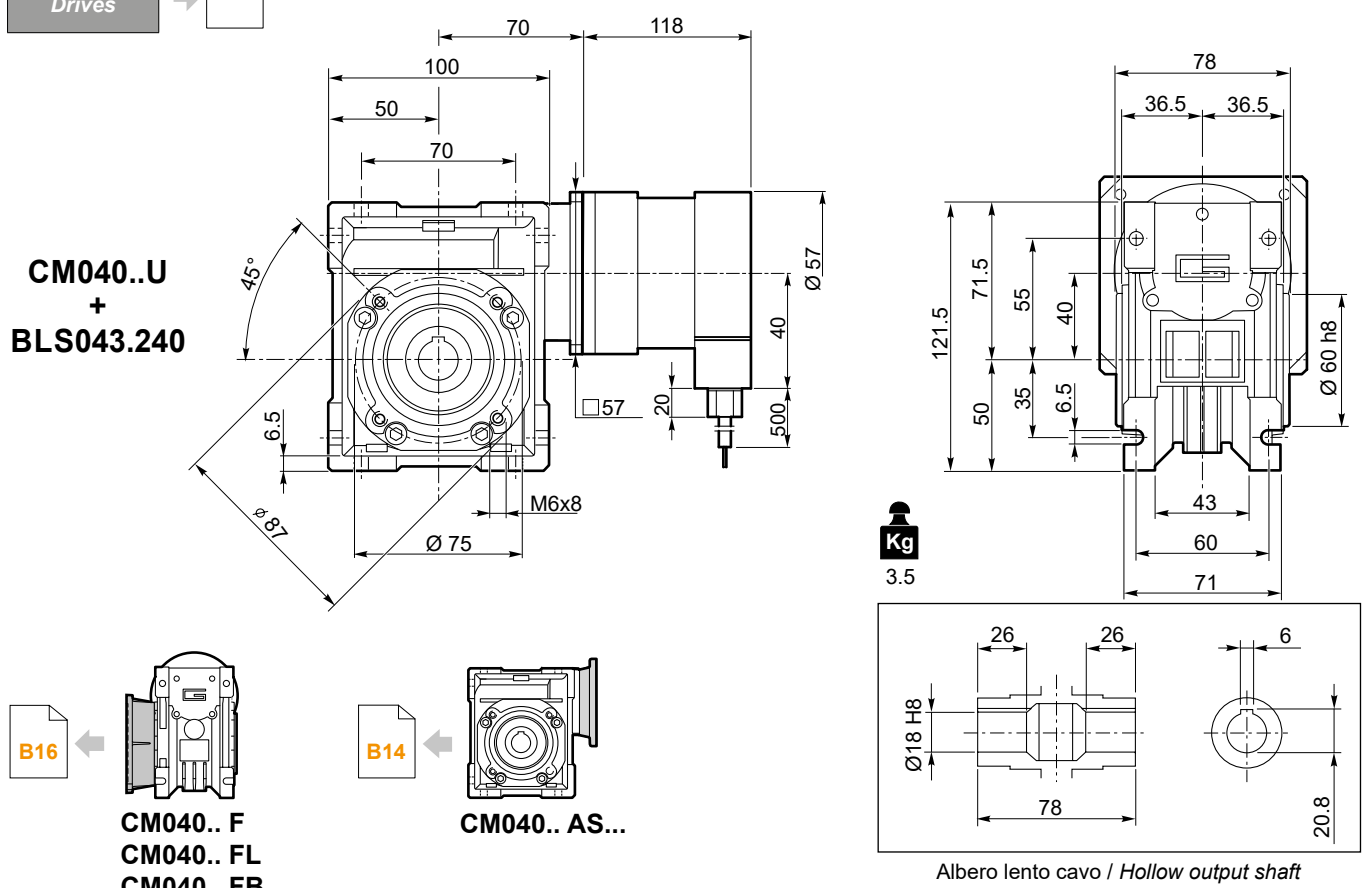

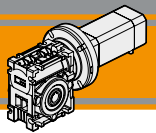

CM040 con motore brushless CC

CM040 with brushless DC motor

CM040	BL070.240 BL070.480 / BL070.48B						BL140.480						BL210.480 / BL210.48E						
	24V / 48V						48V						48V						
	n <sub>2</sub> MIN		n <sub>2</sub> MAX		n <sub>1</sub> MAX		n <sub>2</sub> MIN		n <sub>2</sub> MAX		n <sub>1</sub> MAX		n <sub>2</sub> MIN		n <sub>2</sub> MAX		n <sub>1</sub> MAX		
ir	M <sub>2</sub>	sf	M <sub>2</sub>	sf	[rpm]	M <sub>2</sub>	sf	M <sub>2</sub>	sf	[rpm]	M <sub>2</sub>	sf	M <sub>2</sub>	sf	[rpm]	M <sub>2</sub>	sf	[rpm]	
5	60	2.9	25	600	3.2	9.2	60	5.8	13	600	6.3	4.6	60	8.6	8.5	600	9.4	3.1	3000
7.5	40	4.2	18	400	4.7	6.6	40	8.4	9.0	400	9.3	3.3	40	12	6.1	400	14	2.2	3000
10	30	5.3	14	300	6.1	5.4	30	11	7.1	300	12	2.7	30	16	4.7	300	18	1.8	3000
15	20	7.4	11	200	8.8	3.9	20	15	5.1	200	18	2.0	20	22	3.6	200	27	1.3	3000
20	15	9.5	7.1	150	12	2.6	15	19	3.6	150	23	1.3	15	29	2.3	150	35	0.9	3000
25	12	11	5.4	120	14	2.0	12	22	2.8	120	28	1.0	12	34	1.8	120	42	0.7	3000
30	10	12	6.7	100	16	2.3	10	24	3.4	100	32	1.2	10	37	2.2	100	49	0.8	3000
40	7.5	15	4.5	75	20	1.6	8	29	2.4	75	41	0.8	7.5	45	1.5	75	52	0.7	3000
50	6.0	17	3.7	60	24	1.3	6	33	1.9	60	41	0.7	6.0	50	1.2	60	41	0.7	3000
60	5.0	19	3.0	50	28	1.0	5	37	1.5	50	36	0.7	5.0	57	1.0	50	36	0.7	3000
80	3.7	22	2.2	38	34	0.8	4	43	1.2	38	39	0.7	3.7	66	0.7	38	39	0.7	3000
100	3.0	24	1.8	30	33	0.7	3	47	1.0	30	33	0.7	3.0	63	0.7	30	33	0.7	3000

Attenzione: superamento della coppia nominale supportata dal riduttore per servizio S1. Contattare il ns. servizio tecnico  
Attention: rated torque withstood by gear reducer for service in S1 is exceeded. Please, contact our technical office.

Tipo Type	Numero di poli Number of poles	Numero di fasi Number of phase	Tensione Rated voltage [V]	Numero di giri Rated speed [rpm]	Coppia nominale Rated torque [Nm]	Potenza nominale Rated power [W]
BL070.240	8	3	24	3000	0.7	220
BL070.480 BL070.48B	8	3	48	3000	0.7	220
BL140.480	8	3	48	3000	1.4	440
BL210.480 BL210.48E	8	3	48	3000	2.1	660
Tipo Type	Coppia massima Peak torque [Nm]	Corrente nominale Rated current [A]	Resistenza Resistance [ohm]	Induttanza Inductance [mH]	Corrente massima Peak current [A]	Peso Weight [kg]
BL070.240	2.1	13	0.091	0.23	26	2.1
BL070.480 BL070.48B	1.4	6.5	0.34	1.0	13	2.1
BL140.480	2.8	13	0.16	0.5	26	3.15
BL210.480 BL210.48E	4.2	18.7	0.115	0.31	37	4.2

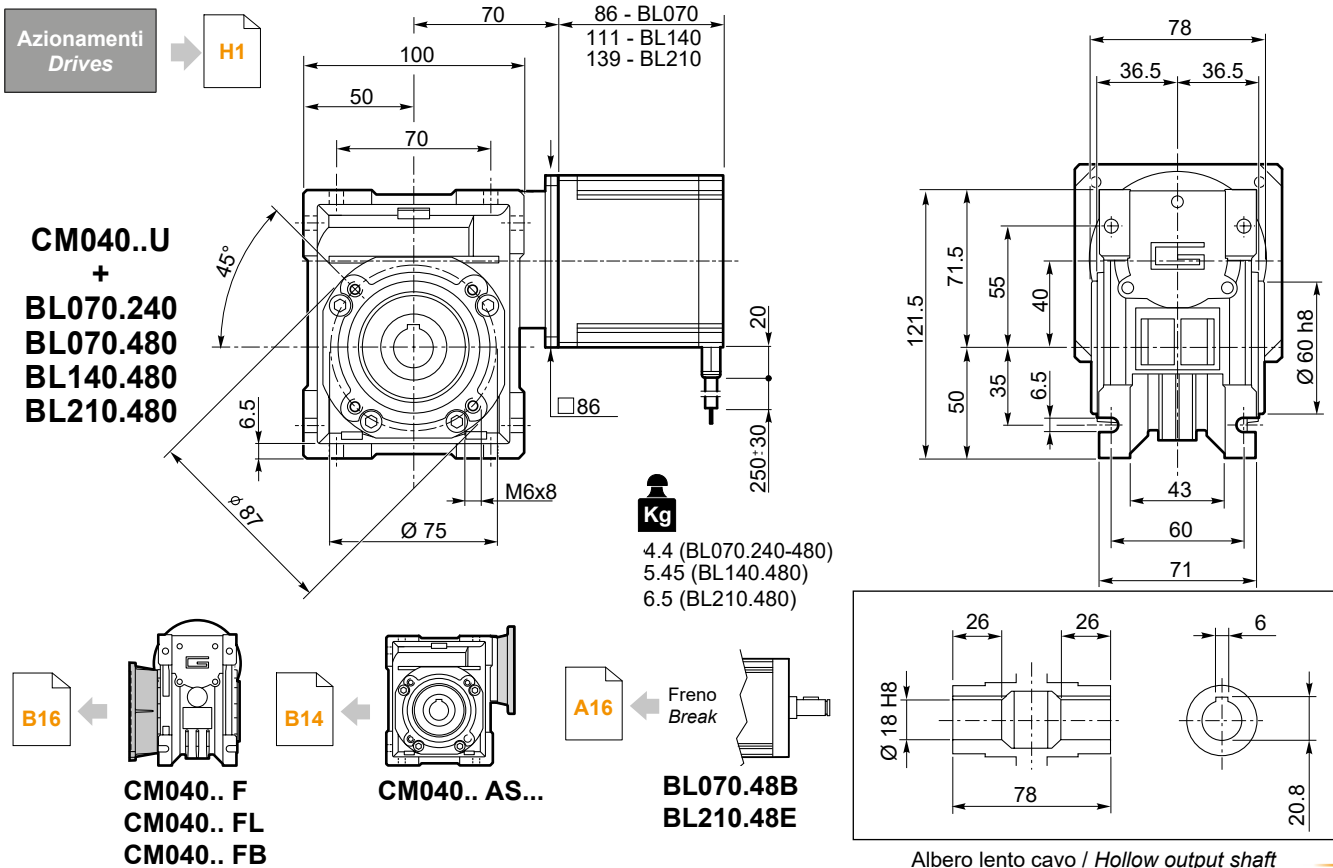

Brushless DC

CM

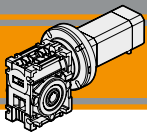

# Motoriduttori brushless CC a vite senza fine Brushless DC Wormgearmotors

CM050 con motore brushless CC

CM050 with brushless DC motor

CM050	BL070.240 BL070.480 / BL070.48B						BL140.480						BL210.480 / BL210.48E						
	24V / 48V						48V						48V						
	n <sub>2</sub> MIN		n <sub>2</sub> MAX		n <sub>1</sub> MAX		n <sub>2</sub> MIN		n <sub>2</sub> MAX		n <sub>1</sub> MAX		n <sub>2</sub> MIN		n <sub>2</sub> MAX		n <sub>1</sub> MAX		
ir	M <sub>2</sub>	sf	M <sub>2</sub>	sf	[rpm]	M <sub>2</sub>	sf	M <sub>2</sub>	sf	[rpm]	M <sub>2</sub>	sf	M <sub>2</sub>	sf	[rpm]	M <sub>2</sub>	sf	[rpm]	
5	60	3.0	46.4	600	3.3	16.0	60	5.8	24	600	6.4	8.5	60	8.7	16	600	9.6	5.6	3000
7.5	40	4.2	33.1	400	4.7	12.1	40	8.5	17	400	9.5	6.0	40	12	11	400	14	4.0	3000
10	30	5.4	26.2	300	6.2	9.7	30	11	13	300	12	4.9	30	16	8.9	300	19	3.2	3000
15	20	7.6	18.4	200	9.0	6.9	20	15	9.2	200	18	3.4	20	23	6.5	200	28	2.2	3000
20	15	9.4	13.3	150	11.8	4.7	15	19	6.6	150	24	2.3	15	29	4.5	150	35	1.6	3000
25	12	11	10.3	120	14.4	3.6	12	22	5.1	120	29	1.8	12	34	3.4	120	43	1.2	3000
30	10	12	12.4	100	16.4	4.1	10	24	6.2	100	33	2.0	10	37	4.2	100	52	1.3	3000
40	7.5	15	8.5	75	20.7	2.8	8	30	4.3	75	41	1.4	7.5	45	2.9	75	62	1.0	3000
50	6.0	17	7.1	60	24.9	2.3	6	34	3.6	60	50	1.1	6.0	50	2.4	60	75	0.8	3000
60	5.0	18	5.7	50	28.6	1.8	5	37	2.9	50	57	0.9	5.0	55	2.0	50	74	0.7	3000
80	3.7	21	4.3	38	34.7	1.3	4	43	2.1	38	66	0.7	3.7	60	1.4	38	66	0.7	3000
100	3.0	23	3.6	30	40.6	1.1	3	47	1.8	30	61	0.7	3.0	71	1.2	30	61	0.7	3000

Attenzione: superamento della coppia nominale supportata dal riduttore per servizio S1. Contattare il ns. servizio tecnico  
Attention: rated torque withstood by gear reducer for service in S1 is exceeded. Please, contact our technical office.

Tipo Type	Numero di poli Number of poles	Numero di fasi Number of phase	Tensione Rated voltage [V]	Numero di giri Rated speed [rpm]	Coppia nominale Rated torque [Nm]	Potenza nominale Rated power [W]
BL070.240	8	3	24	3000	0.7	220
BL070.480 BL070.48B	8	3	48	3000	0.7	220
BL140.480	8	3	48	3000	1.4	440
BL210.480 BL210.48E	8	3	48	3000	2.1	660

Tipo Type	Coppia massima Peak torque [Nm]	Corrente nominale Rated current [A]	Resistenza Resistance [ohm]	Induttanza Inductance [mH]	Corrente massima Peak current [A]	Peso Weight [kg]
BL070.240	2.1	13	0.091	0.23	26	2.1
BL070.480 BL070.48B	1.4	6.5	0.34	1.0	13	2.1
BL140.480	2.8	13	0.16	0.5	26	3.15
BL210.480 BL210.48E	4.2	18.7	0.115	0.31	37	4.2

Azionamenti Drives

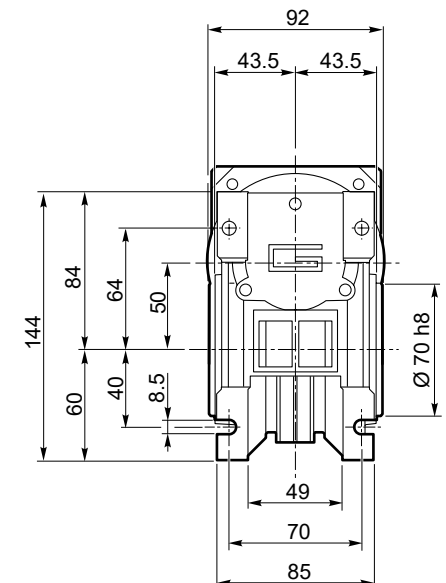
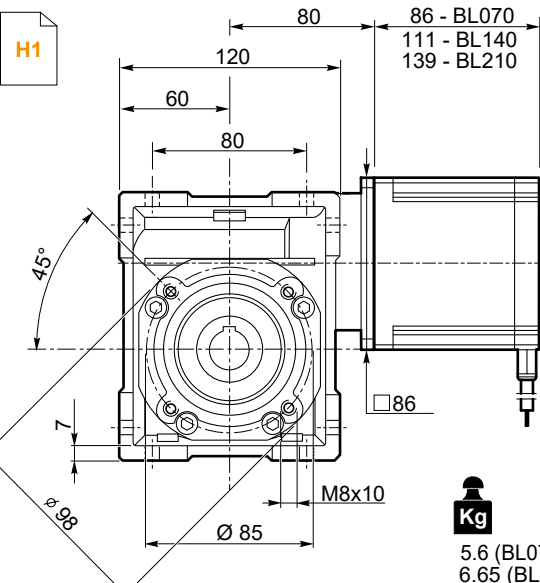

CM050..U  
+  
BL070.240  
BL070.480  
BL140.480  
BL210.480

**Kg**  
5.6 (BL070.240-480)  
6.65 (BL140.480)  
7.7 (BL210.480)

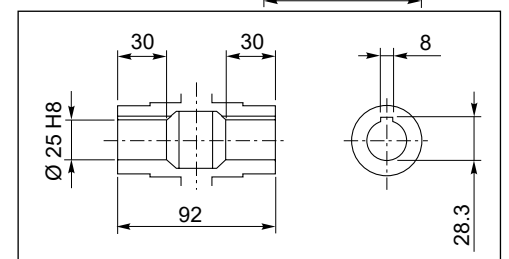
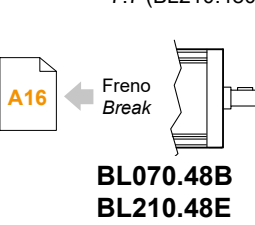
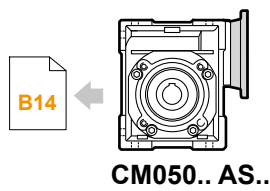
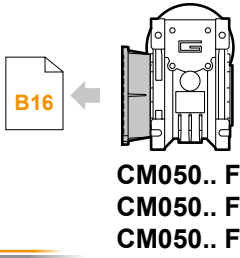

Albero lento cavo / Hollow output shaft

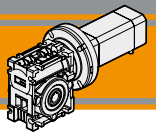

CM063 con motore brushless CC

CM063 with brushless DC motor

CM063	BL070.240 BL070.480 / BL070.48B						BL140.480						BL210.480 / BL210.48E								
	24V / 48V						48V						48V								
	n <sub>2</sub> MIN		n <sub>2</sub> MAX		n <sub>1</sub> MAX		n <sub>2</sub> MIN		n <sub>2</sub> MAX		n <sub>1</sub> MAX		n <sub>2</sub> MIN		n <sub>2</sub> MAX		n <sub>1</sub> MAX				
ir	M <sub>2</sub>	sf	M <sub>2</sub>	sf	[rpm]	M <sub>2</sub>	sf	M <sub>2</sub>	sf	[rpm]	M <sub>2</sub>	sf	M <sub>2</sub>	sf	[rpm]	M <sub>2</sub>	sf	[rpm]			
40	7.5	15	15.7	75	21	5.3	3000	8	31	7.9	75	43	2.6	3000	7.5	46	5.2	75	64	1.8	3000
50	6.0	18	12.2	60	26	4.0		6	36	6.1	60	51	2.0		6.0	53	4.1	60	77	1.3	
60	5.0	20	10.1	50	30	3.3		5	40	5.1	50	59	1.6		5.0	59	3.4	50	88	1.1	
80	3.7	23	7.7	38	36	2.4		4	45	3.8	38	73	1.2		3.7	68	2.6	38	109	0.8	
100	3.0	25	6.3	30	42	1.9		3	50	3.1	30	84	1.0		3.0	75	2.1	30	114	0.7	

Attenzione: superamento della coppia nominale supportata dal riduttore per servizio S1. Contattare il ns. servizio tecnico  
Attention: rated torque withstood by gear reducer for service in S1 is exceeded. Please, contact our technical office.

Tipo Type	Numero di poli Number of poles	Numero di fasi Number of phase	Tensione Rated voltage [ V ]	Numero di giri Rated speed [ rpm ]	Coppia nominale Rated torque [ Nm ]	Potenza nominale Rated power [ W ]
BL070.240	8	3	24	3000	0.7	220
BL070.480 BL070.48B	8	3	48	3000	0.7	220
BL140.480	8	3	48	3000	1.4	440
BL210.480 BL210.48E	8	3	48	3000	2.1	660

  

Tipo Type	Coppia massima Peak torque [ Nm ]	Corrente nominale Rated current [ A ]	Resistenza Resistance [ ohm ]	Induttanza Inductance [ mH ]	Corrente massima Peak current [ A ]	Peso Weight [ kg ]
BL070.240	2.1	13	0.091	0.23	26	2.1
BL070.480 BL070.48B	1.4	6.5	0.34	1.0	13	2.1
BL140.480	2.8	13	0.16	0.5	26	3.15
BL210.480 BL210.48E	4.2	18.7	0.115	0.31	37	4.2

Azionamenti  
Drives



CM063..U  
+  
BL070.240  
BL070.480  
BL140.480  
BL210.480

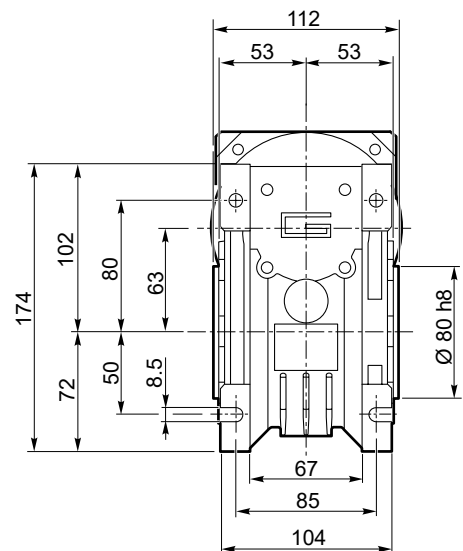
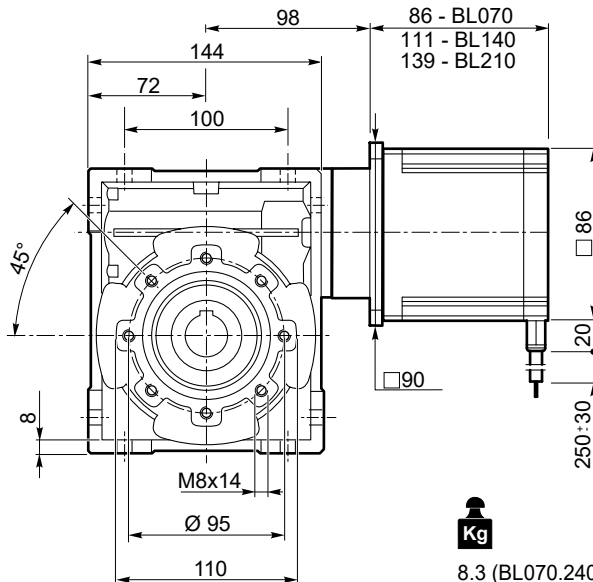

8.3 (BL070.240-480)  
9.35 (BL210.480)  
10.4 (BL210.480)

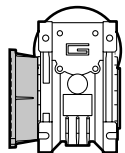

CM063.. F  
CM063.. FL  
CM063.. FB

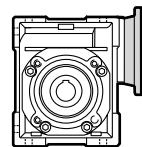

CM063.. AS...

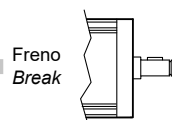

BL070.48B  
BL210.48E

Freno  
Break

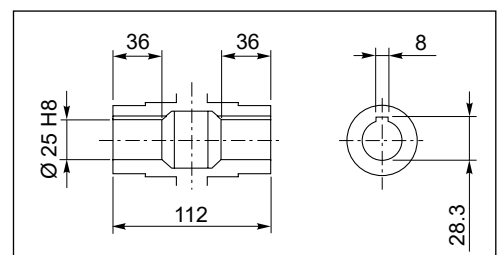

Albero lento cavo / Hollow output shaft

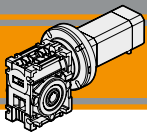



# Motoriduttori brushless CC a vite senza fine

## Brushless DC Wormgearmotors

### Dati tecnici

### Technical data

	$n_2$ [min <sup>-1</sup> ]	$Mn_2$ [Nm]	$Pn_1$ [kW]	$i$
---	-------------------------------	----------------	----------------	-----

	$n_2$ [min <sup>-1</sup> ]	$Mn_2$ [Nm]	$Pn_1$ [kW]	$i$
---	-------------------------------	----------------	----------------	-----

#### CM026

n1 = 1400 rpm	<b>280</b>	13	0.44	5
	<b>187</b>	14	0.33	7,5
	<b>140</b>	14	0.25	10
	<b>93</b>	14	0.18	15
	<b>70</b>	14	0.14	20
	<b>47</b>	15	0.11	30
	<b>35</b>	14	0.08	40
	<b>28</b>	13	0.07	50
	<b>23</b>	12	0.06	60

#### CM026

n1 = 3000 rpm	<b>600</b>	10	0.71	5
	<b>400</b>	11	0.53	7,5
	<b>300</b>	11	0.41	10
	<b>200</b>	11	0.28	15
	<b>150</b>	11	0.22	20
	<b>100</b>	12	0.17	30
	<b>75</b>	11	0.13	40
	<b>60</b>	10	0.10	50
	<b>50</b>	9	0.08	60

#### CM030

n1 = 1400 rpm	<b>280</b>	18	0.61	5
	<b>187</b>	20	0.46	7,5
	<b>140</b>	21	0.37	10
	<b>93</b>	21	0.26	15
	<b>70</b>	19	0.19	20
	<b>56</b>	20	0.16	25
	<b>47</b>	22	0.16	30
	<b>35</b>	20	0.12	40
	<b>28</b>	19	0.10	50
	<b>23</b>	17	0.08	60
	<b>18</b>	15	0.06	80
	<b>14</b>	14	0.05	100

#### CM030

n1 = 3000 rpm	<b>600</b>	13	0.92	5
	<b>400</b>	15	0.71	7,5
	<b>300</b>	16	0.58	10
	<b>200</b>	16	0.40	15
	<b>150</b>	14	0.27	20
	<b>120</b>	15	0.24	25
	<b>100</b>	18	0.25	30
	<b>75</b>	16	0.18	40
	<b>60</b>	15	0.14	50
	<b>50</b>	14	0.12	60
	<b>37.5</b>	12	0.08	80
	<b>30</b>	11	0.07	100

#### CM040

n1 = 1400 rpm	<b>280</b>	41	1.37	5
	<b>187</b>	44	1.00	7,5
	<b>140</b>	45	0.79	10
	<b>93</b>	45	0.54	15
	<b>70</b>	40	0.38	20
	<b>56</b>	38	0.30	25
	<b>47</b>	48	0.34	30
	<b>35</b>	42	0.24	40
	<b>28</b>	39	0.19	50
	<b>23</b>	36	0.15	60
	<b>18</b>	33	0.12	80
	<b>14</b>	31	0.10	100

#### CM040

n1 = 3000 rpm	<b>600</b>	29	2.02	5
	<b>400</b>	31	1.46	7,5
	<b>300</b>	33	1.19	10
	<b>200</b>	35	0.87	15
	<b>150</b>	31	0.59	20
	<b>120</b>	28	0.44	25
	<b>100</b>	38	0.52	30
	<b>75</b>	34	0.37	40
	<b>60</b>	32	0.29	50
	<b>50</b>	29	0.23	60
	<b>37.5</b>	27	0.18	80
	<b>30</b>	24	0.13	100

#### CM050

n1 = 1400 rpm	<b>280</b>	75	2.5	5
	<b>187</b>	79	1.8	7,5
	<b>140</b>	82	1.4	10
	<b>93</b>	82	0.98	15
	<b>70</b>	72	0.67	20
	<b>56</b>	70	0.54	25
	<b>47</b>	88	0.60	30
	<b>35</b>	76	0.42	40
	<b>28</b>	72	0.34	50
	<b>23</b>	69	0.28	60
	<b>18</b>	60	0.20	80
	<b>14</b>	56	0.17	100

#### CM050

n1 = 3000 rpm	<b>600</b>	54	3.73	5
	<b>400</b>	57	2.65	7,5
	<b>300</b>	60	2.14	10
	<b>200</b>	62	1.51	15
	<b>150</b>	55	1.03	20
	<b>120</b>	51	0.78	25
	<b>100</b>	67	0.90	30
	<b>75</b>	59	0.63	40
	<b>60</b>	57	0.50	50
	<b>50</b>	52	0.40	60
	<b>37.5</b>	46	0.29	80
	<b>30</b>	43	0.23	100

#### CM063

n1 = 1400 rpm	<b>280</b>	134	4.4	5
	<b>187</b>	144	3.2	7,5
	<b>140</b>	148	2.5	10
	<b>93</b>	154	1.8	15
	<b>70</b>	136	1.23	20
	<b>56</b>	135	1.0	25
	<b>47</b>	166	1.1	30
	<b>35</b>	142	0.74	40
	<b>28</b>	136	0.60	50
	<b>23</b>	126	0.49	60
	<b>18</b>	118	0.38	80
	<b>14</b>	116	0.33	100

#### CM063

n1 = 3000 rpm	<b>600</b>	97	6.70	5
	<b>400</b>	103	4.79	7,5
	<b>300</b>	110	3.93	10
	<b>200</b>	115	2.80	15
	<b>150</b>	102	1.91	20
	<b>120</b>	94	1.42	25
	<b>100</b>	127	1.68	30
	<b>75</b>	112	1.16	40
	<b>60</b>	103	0.89	50
	<b>50</b>	97	0.73	60
	<b>37.5</b>	87	0.53	80
	<b>30</b>	80	0.42	100



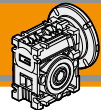

Dimensioni CM con flange motore AS

CM dimensions with motor flanges AS

CM026 - U - AS...

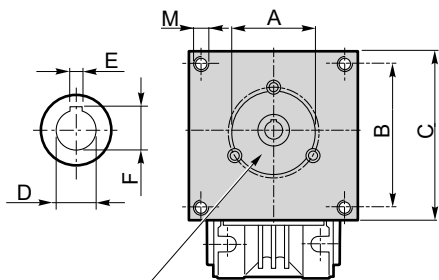

Connessione con boccola o giunto in funzione del diametro dell'albero motore.

Connection with sleeve or coupling depending on motorshaft's diameter.

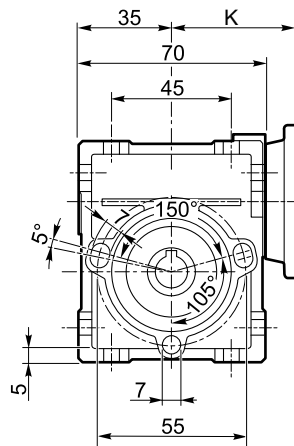

Lo spessore della flangia è variabile in funzione delle diverse lunghezze dell'albero motore.

Flange's thickness may vary depending on motorshaft's lenght.

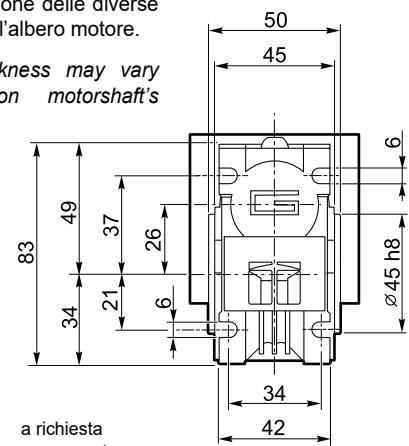

a richiesta  
on request



CM026.. F

CL026...

**Kg**  
0.8

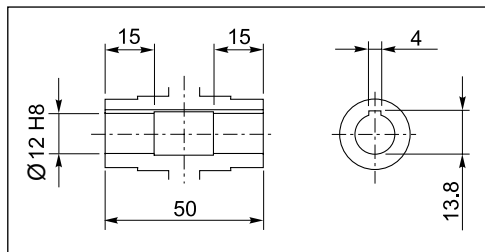

Albero lento cavo / Hollow output shaft

Dimensioni / Dimensions						Rapporti / Ratio		
AS	A	B	C	M	K	5...100		
						D	E	F
AS417	38.1	47.1	56	M4	49.5	9	3	10.4
...	...	...	...	...	...	...	...	...

CM030 - U - AS...

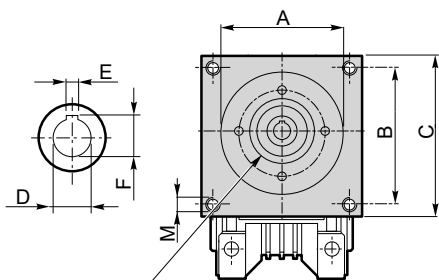

Connessione con boccola o giunto in funzione del diametro dell'albero motore.

Connection with sleeve or coupling depending on motorshaft's diameter.

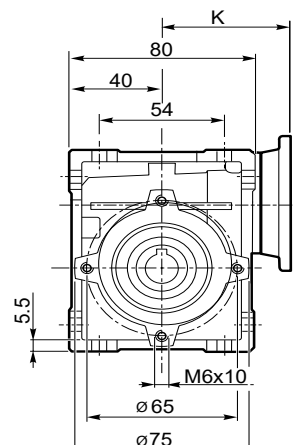

Lo spessore della flangia è variabile in funzione delle diverse lunghezze dell'albero motore.

Flange's thickness may vary depending on motorshaft's lenght.

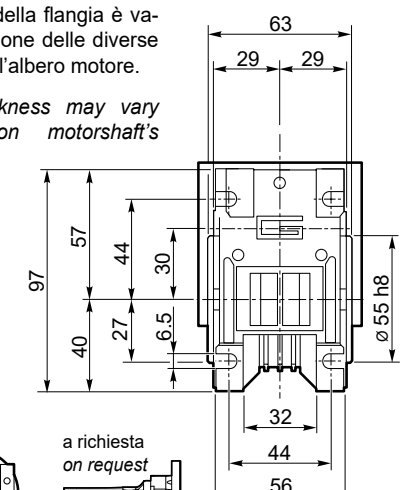

a richiesta  
on request



CM030.. F

CL030...

**Kg**  
1.2

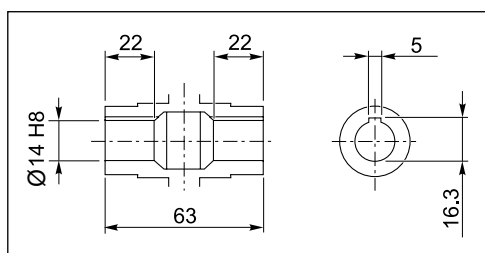

Albero lento cavo / Hollow output shaft

Dimensioni / Dimensions						Rapporti / Ratio					
AS	A	B	C	M	K	5...50			60...100		
						D	E	F	D	E	F
AS393	38.1	47.1	57	M5	55	11	4	12.8	9	3	10.4
AS391	73	69.6	86	M5	55	11	4	12.8	9	3	10.4
...	...	...	...	...	...	...	...	...	...	...	...

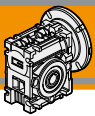

**CM**

Riduttori a vite senza fine  
Wormgearboxes

**Dimensioni CM con flange motore AS**

**CM dimensions with motor flanges AS**

**CM040 - U - AS...**

Lo spessore della flangia è variabile in funzione delle diverse lunghezze dell'albero motore.

Flange's thickness may vary depending on motorshaft's lenght.

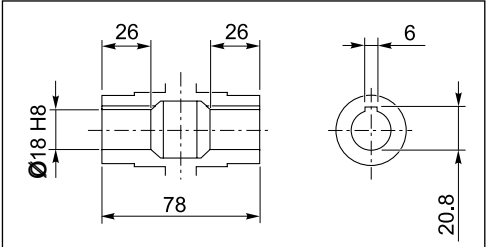
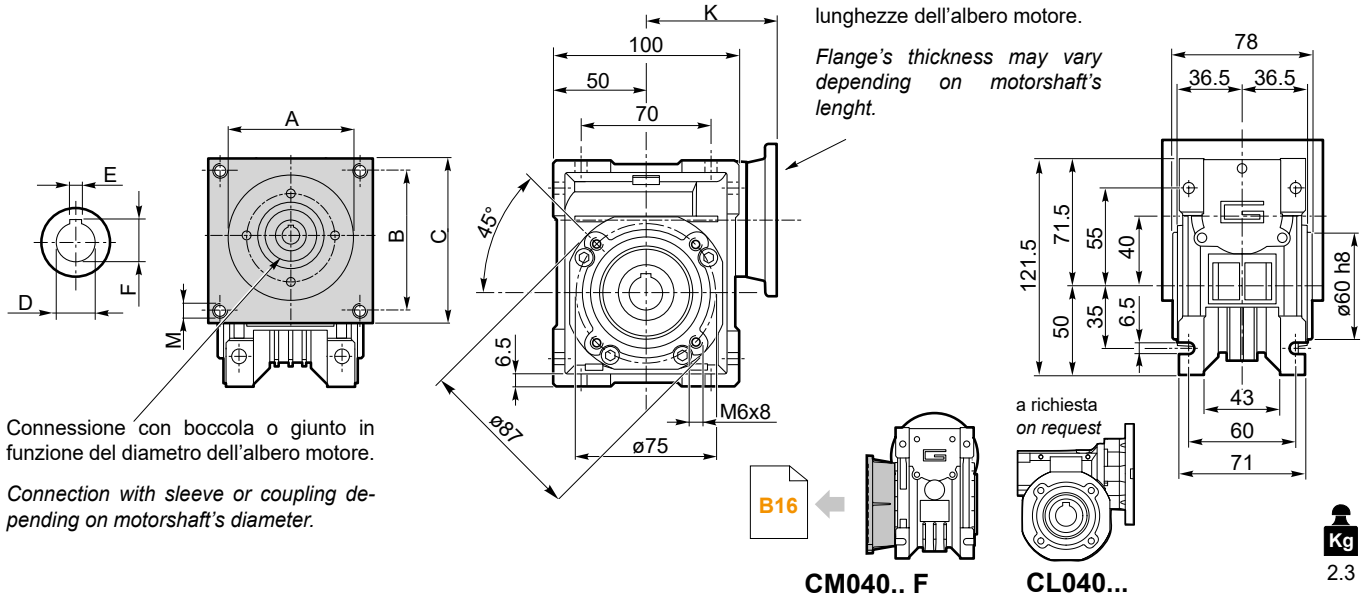

Dimensioni / Dimensions						Rapporti / Ratio					
AS	A	B	C	M	K	5...40			50...100		
						D	E	F	D	E	F
AS392	38.1	47.1	64	M5	70	14	5	16.3	11	4	12.8
AS384	73	69.6	86	M5	70	14	5	16.3	11	4	12.8
...	...	...	...	...	...	...	...	...	...	...	...

**CM050 - U - AS...**

Lo spessore della flangia è variabile in funzione delle diverse lunghezze dell'albero motore.

Flange's thickness may vary depending on motorshaft's lenght.

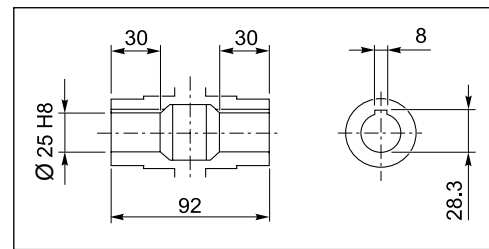
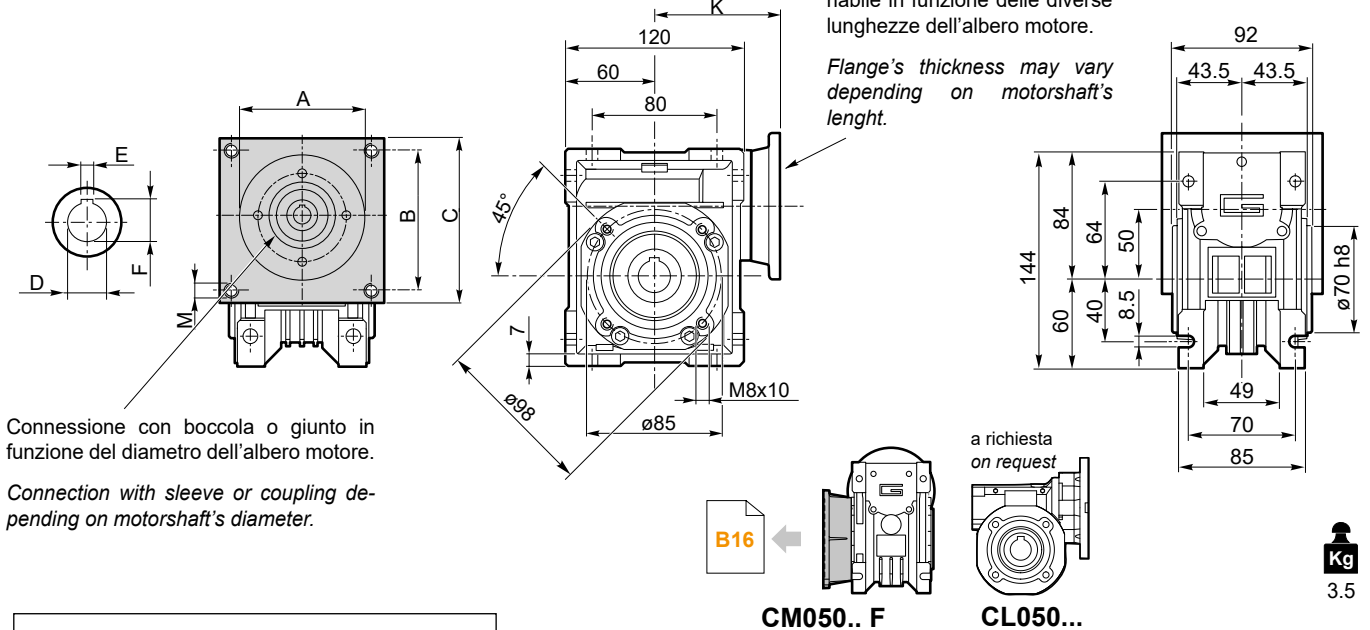

Dimensioni / Dimensions						Rapporti / Ratio								
AS	A	B	C	M	K	5...30			40...80		100			
						D	E	F	D	E	F	D	E	F
AS363	73	69.5	86	M5	80	19	6	21.8	14	5	16.3	11	4	12.8
...	...	...	...	...	...	...	...	...	...	...	...	...	...	...

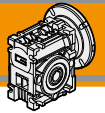

Dimensioni CM con flange motore AS

CM dimensions with motor flanges AS

CM063 - U - AS...

Lo spessore della flangia è variabile in funzione delle diverse lunghezze dell'albero motore.

Flange's thickness may vary depending on motorshaft's length.

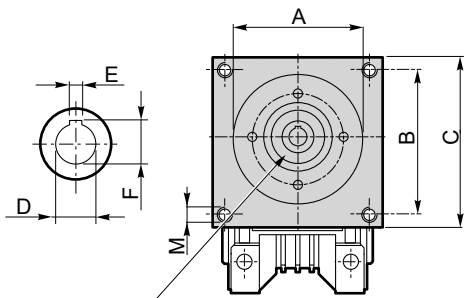

Connessione con boccola o giunto in funzione del diametro dell'albero motore.

Connection with sleeve or coupling depending on motorshaft's diameter.

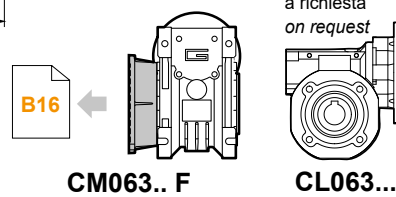
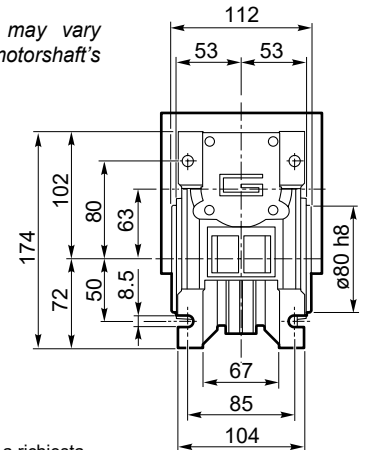
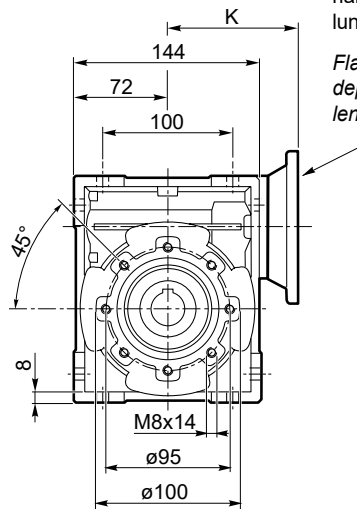

**Kg**  
6.2

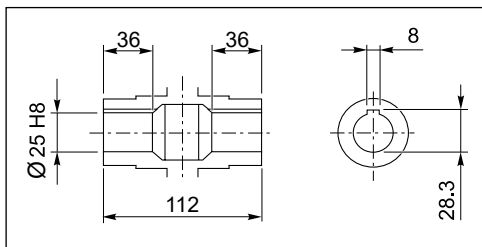

Albero lento cavo / Hollow output shaft

Dimensioni / Dimensions														
AS	A	B	C	M	K	Rapporti / Ratio								
						5...30			40...60			80...100		
						D	E	F	D	E	F	D	E	F
AS302	73	69.6	86	M5	80	24	8	27.3	19	6	21.8	14	5	16.3
...	...	...	...	...	...	...	...	...	...	...	...	...	...	...

Brushless DC  
CM

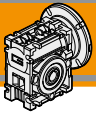

**CM**

Riduttori a vite senza fine  
Wormgearboxes

**Dimensioni flange uscita**

**Output flange dimensions**

**CM.../... F...** Flange uscita / Output flanges

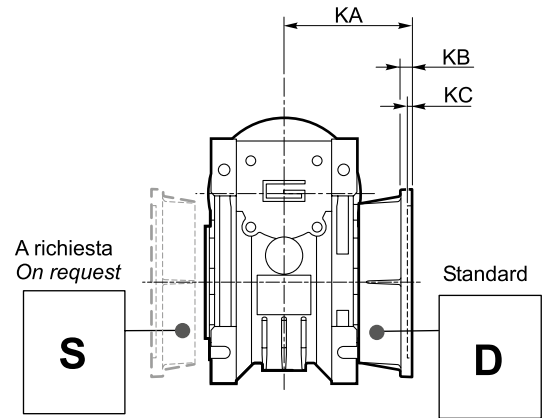
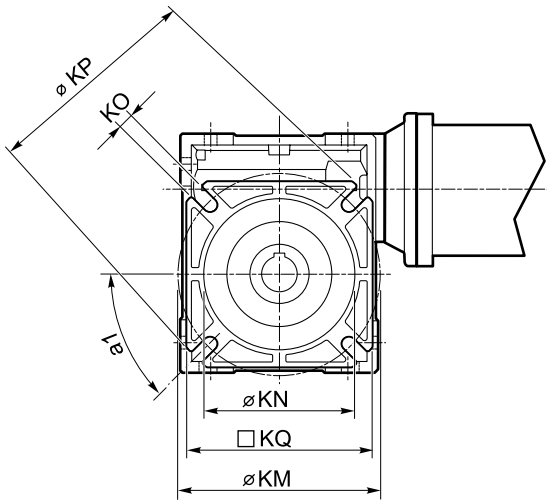

CM	CM..F									CM..FB							CM..FL								
	a1	KA	KB	KC	KM	KN <sub>H8</sub>	KO	KP	KQ	KA	KB	KC	KM	KN <sub>H8</sub>	KO	KP	KQ	KA	KB	KC	KM	KN <sub>H8</sub>	KO	KP	KQ
026	45°	45	6	4.5	55-69	40	6.5(n.4)	75	70	—	—	—	—	—	—	—	—	—	—	—	—	—	—	—	—
030	45°	54.5	6	4	68	50	6.5(n.4)	80	70	—	—	—	—	—	—	—	—	—	—	—	—	—	—	—	—
040	45°	67	7.5	4	80-95	60	9(n.4)	110	95	80	8.5	5	115-125	95	9.5(n.4)	140	112	97	7.5	4.5	80-95	60	9(n.4)	110	95
050	45°	90	9	5	90-110	70	11(n.4)	125	110	89	9	5	130-145	110	9.5(n.4)	160	132	120	9	5	90-110	70	11(n.4)	125	110
063	45°	82	10	6	150-160	115	11(n.4)	180	142	98	10	5	165-180	130	11(n.4)	200	160	112	10	6	150-160	115	11(n.4)	180	142

**Opzioni**

**Options**

**VS - Vite sporgente / Extended input shaft**

**SC - Safety cover**

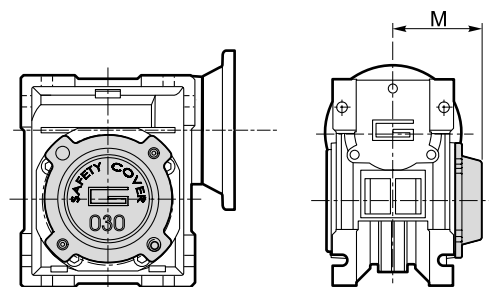
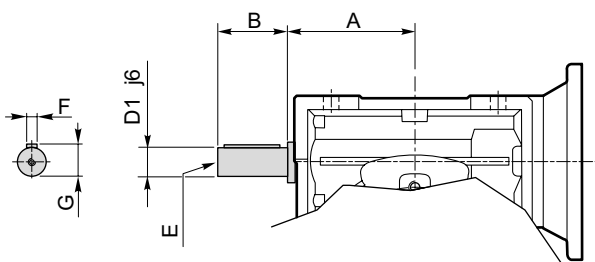

	A	B	D <sub>1</sub> j6	E	F	G
CM 030	45	20	9	M4	3	10.2
CM 040	53	23	11	M5	4	12.5
CM 050	64	30	14	M6	5	16
CM 063	75	40	19	M6	6	21.5

	M
CM 030	47
CM 040	54.5
CM 050	62.5
CM 063	73

Costruito su richiesta  
Built on request

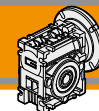

Accessori

Accessories

Albero lento

Output shaft

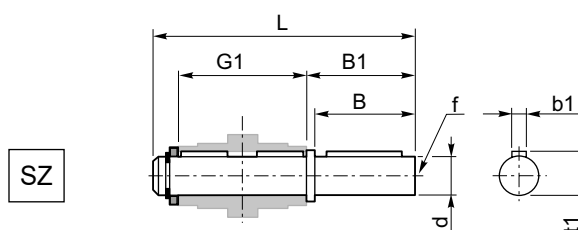
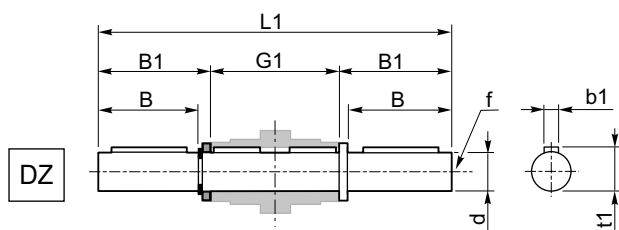

	d h7	B	B1	G1	L	L1	f	b1	t1
CM 030	14	30	32.5	63	102	128	M6	5	16
CM 040	18	40	43	78	128	164	M6	6	20.5
CM 050	25	50	53.5	92	153	199	M10	8	28
CM 063	25	50	53.5	112	173	219	M10	8	28

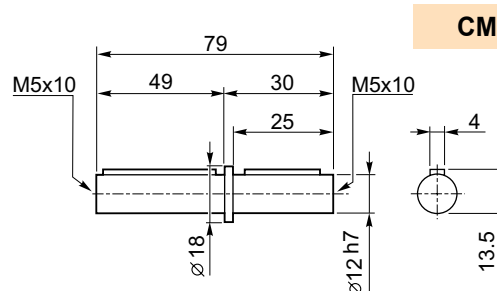

CM 026

Braccio di reazione

Torque arm

	K1	G	KG	KH	R
CM 030	85	14	23	8	15
CM 040	100	14	31	10	18
CM 050	100	14	38	10	18
CM 063	150	14	47.5	10	18

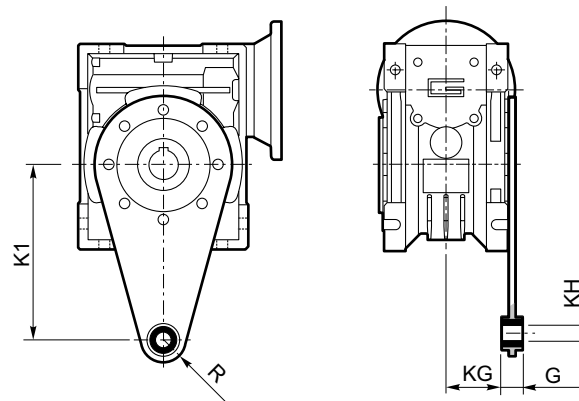

## Wir kombinieren Elektronik und Mechanik für Sie. Und das seit über 70 Jahren.

Die Ott GmbH & Co. KG bietet als Produktions-, Handels- und Dienstleistungsunternehmen Komponenten und Systeme aus dem Bereich der Antriebstechnik und Elektronik an. Wir sehen uns als Produzent, Modifikator und Händler von Antrieben und Steuerungen und sind als verlässlicher Business-Partner bekannt. Aufgrund der hohen Qualität und Langlebigkeit unserer Produkte, genießen wir einen hervorragenden Ruf in der Industrie.

Als Vertretung unter anderem der Firmen Nidec, DKM, Transtecno, Ewellix und Kaleja führen wir ein Lager, in dem ständig circa 100.000 Motoren und Steuerungen vorrätig gehalten werden. Dies ermöglicht es, schnell auf Ihre Anforderungen zu reagieren. Darüber hinaus werden in unserer eigenen Fertigung kundenspezifische Änderungen an Motoren, wie Wellenbearbeitungen, Aufbau von Inkrementalgebern, Bremsen, Sonder-getriebe und Steckverbindungen, realisiert.

Diese Sonderfertigungen führen wir auch bei kleinsten Stückzahlen durch.

Damit können komplette Systemlösungen nach Ihren Aufgabenstellungen projiziert und gefertigt werden. Um die optimale Lösung für jedes Projekt zu erarbeiten, stehen unsere erfahrenen und langjährigen Vertriebsingenieure mit kompetentem Fachwissen jederzeit zur Verfügung.

Unser Vorgehen: Wir informieren uns über Ihre Anforderungen, wählen mit Ihrer Entwicklungsabteilung die passenden Antriebe und Steuerungen aus und erarbeiten wirtschaftliche Systemlösungen.

**Gemäß dem Slogan „Standardisierte Individualität“ wird wo möglich eine Standard- und wo nötig eine individuelle Lösung erarbeitet.**



Kataloge entdecken



**Ott GmbH & Co. KG**  
Baarstraße 3 • D-78652 Deißlingen  
Telefon: +49 7420 / 9399-0

info@ott-antriebe.de  
[www.ott-antriebe.de](http://www.ott-antriebe.de)